

FE-13 Component Description

Effective: April 1999

Pressure Trip

K-96-3180

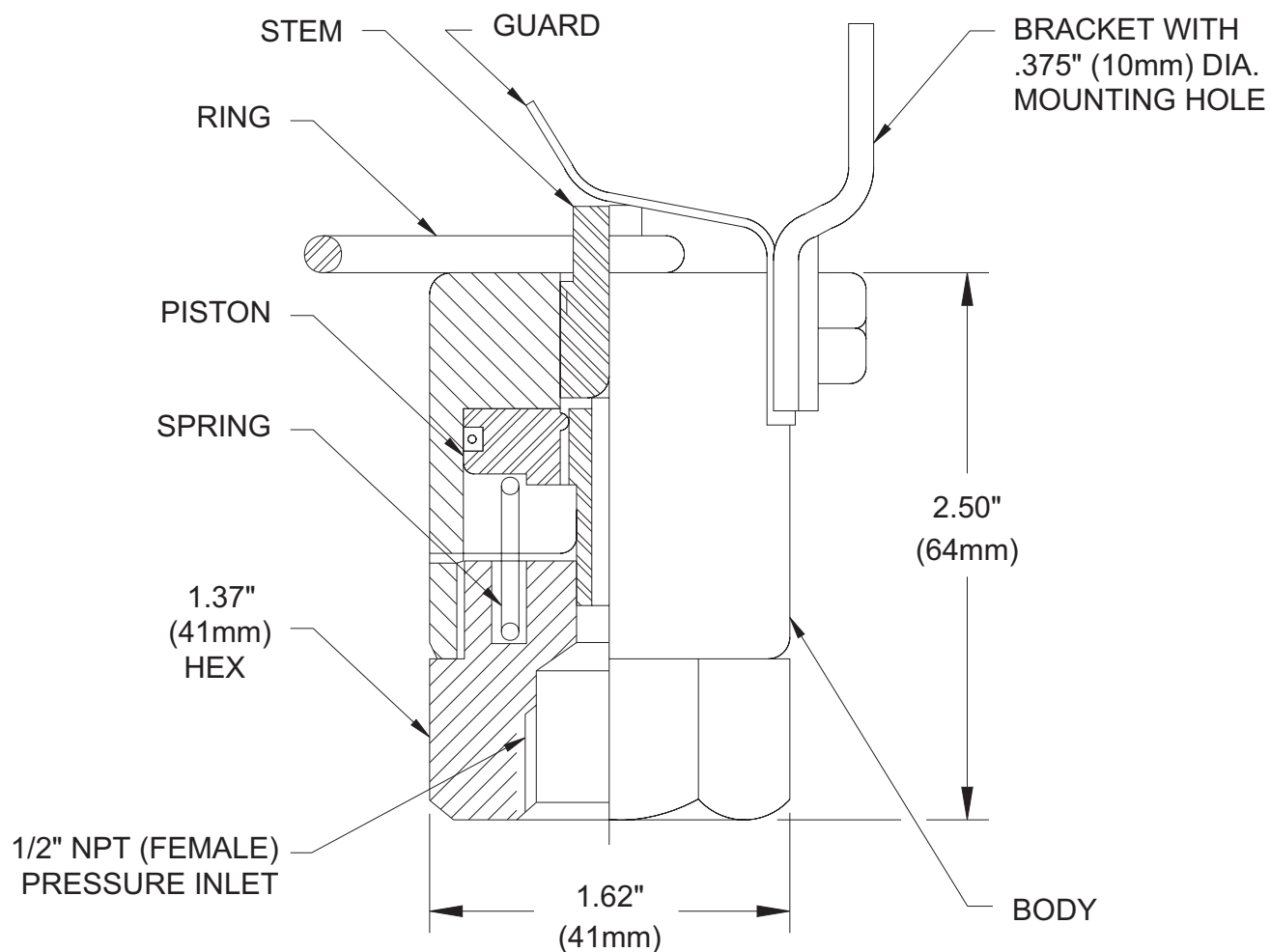

MATERIALS

BODY, BRACKET, AND PISTON: BRASS
GUARD, STEM, RING & SPRING: STAINLESS STEEL

MAXIMUM LOAD ON RING: 100 LBS. (45 KG)
MINIMUM NOMINAL OPERATING PRESSURE: 50 PSI (3.5 BARS)

P/N: 874290

This literature is provided for informational purposes only. KIDDE-FENWAL, INC. assumes no responsibility for the product's suitability for a particular application. The product must be properly applied to perform as described herein.

If you need more information on this product, or if you have a question, contact KIDDE-FENWAL, INC., Ashland, MA 01721. (508) 881-2000.

K-96-3180 4/99 ©1999 Kidde-Fenwal, Inc. Printed in U.S.A.

KIDDE
Fire Systems

KIDDE-FENWAL, INC.
400 MAIN STREET, ASHLAND, MA 01721
TEL: (508) 881-2000 FAX: (508) 881-8920