

FM-200 Component Description

Effective: April 1999

K-90-6070

Features

• *USCG approved*

• *For use in marine applications only*

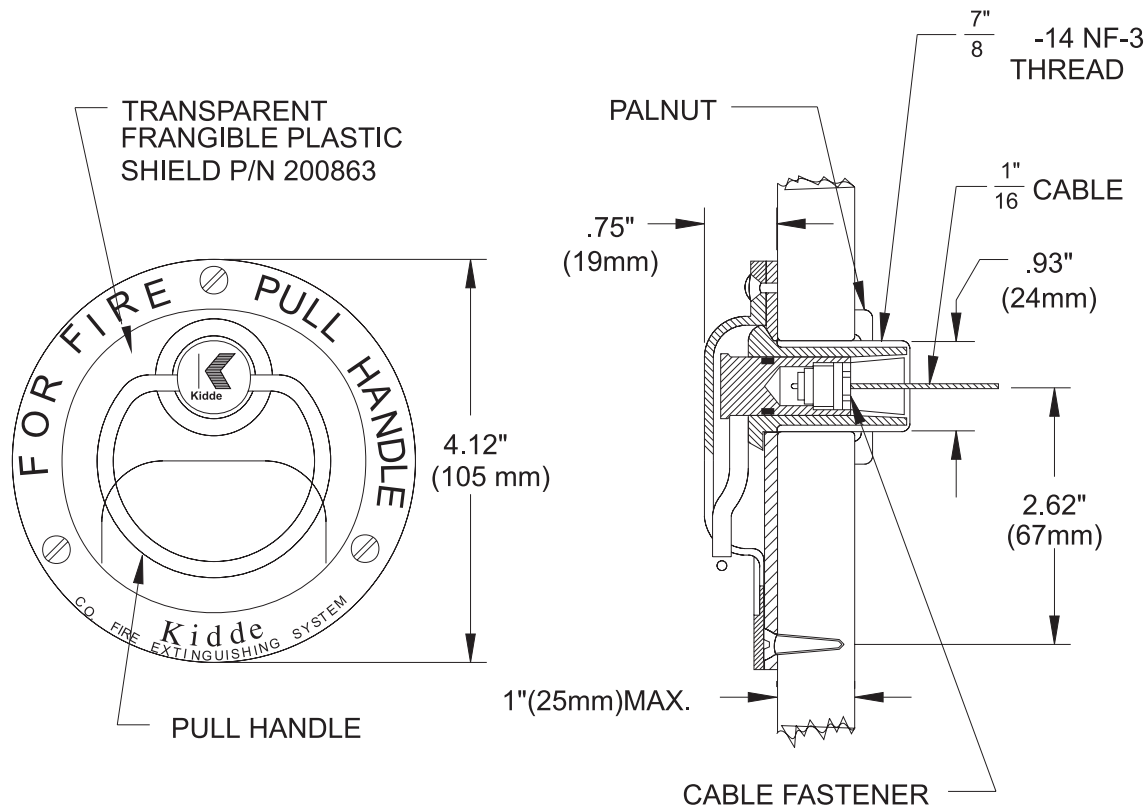

MOUNTING HARDWARE PROVIDED:

3 - 10-32 FLAT HEAD SCREWS - $\frac{1}{2}$ " - (13mm) LONG

3 - NO. 10 FLAT HEAD WOOD SCREWS (SHOWN)

$\frac{3}{4}$ " (19mm) LONG

MATERIALS

FRANGIBLE SHIELD: LUCITE

BODY: BRASS

HANDLE: STAINLESS STEEL

P/N: 840098

This literature is provided for informational purposes only. KIDDE-FENWAL, INC. assumes no responsibility for the product's suitability for a particular application. The product must be properly applied to perform as described herein.

If you need more information on this product, or if you have a question, contact KIDDE-FENWAL, INC., Ashland, MA 01721. (508) 881-2000.

K-90-6070 4/99 ©1999 Kidde-Fenwal, Inc. Printed in U.S.A.

KIDDE[®]
Fire Systems

KIDDE-FENWAL, INC.
400 MAIN STREET, ASHLAND, MA 01721
TEL: (508) 881-2000 FAX: (508) 881-8920

KIDDE[®] Fire Systems