

FM-200 Component Description

Effective: April 1999

K-90-5140

Stop (Directional) Valves, 2-1/2" & 3"

Features

- See KIDDE Manual 90-FM200M-021 for USCG approval

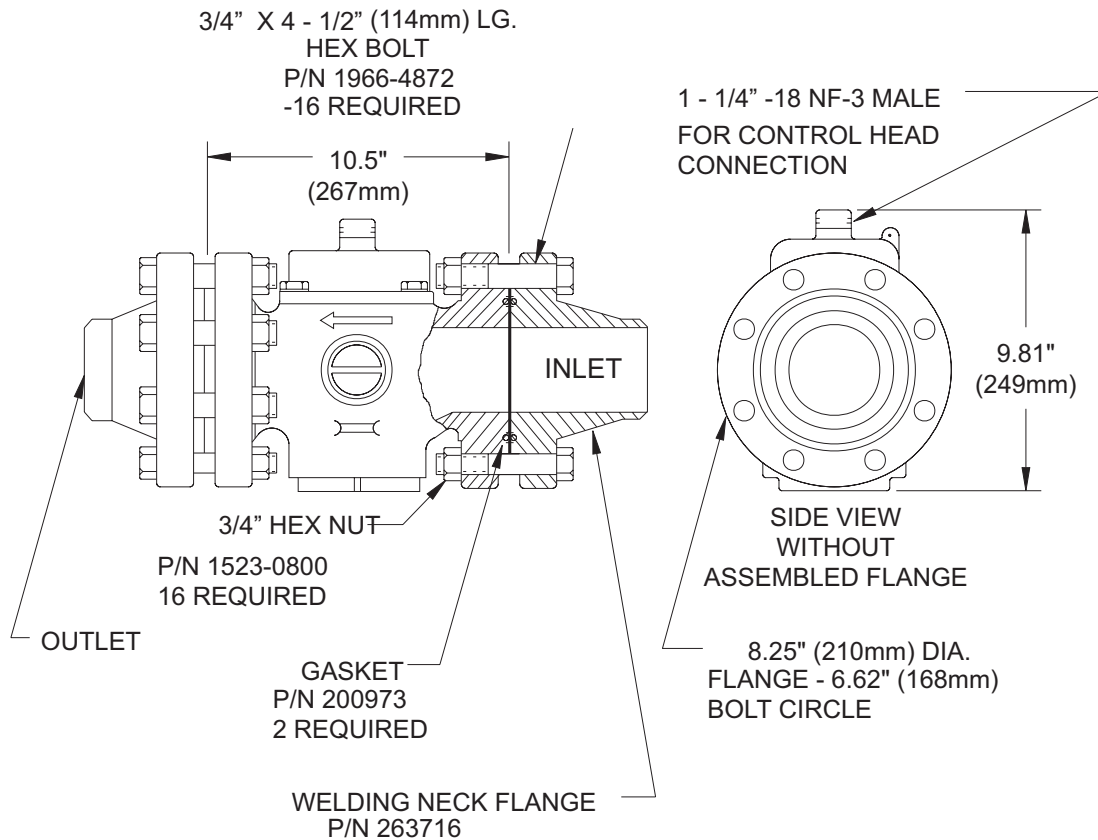

ORDERING INFORMATION

CHECK VALVE SIZE	P/N	WELDING NECK FLANGE P/N (2 REQUIRED)
2-1/2"	890010	263716
3"	890010	6810-1200

MATERIALS

VALVE BODY: BRASS

GASKET: IRON

FLANGES, BOLTS, & NUTS: STEEL

VALVE MUST BE INSTALLED WITH ARROW POINTING IN DIRECTION OF FLOW

P/N: 890010

This literature is provided for informational purposes only. KIDDE-FENWAL, INC. assumes no responsibility for the product's suitability for a particular application. The product must be properly applied to perform as described herein.

If you need more information on this product, or if you have a question, contact KIDDE-FENWAL, INC., Ashland, MA 01721. (508) 881-2000.

K-90-5140 4/99 ©1999 Kidde-Fenwal, Inc. Printed in U.S.A.

KIDDE®
Fire Systems

KIDDE-FENWAL, INC.
400 MAIN STREET, ASHLAND, MA 01721
TEL: (508) 881-2000 FAX: (508) 881-8920