

# CO<sub>2</sub> Component Description

Effective: April 1999

K-81-5150

## 4" Stop (Directional) Valve

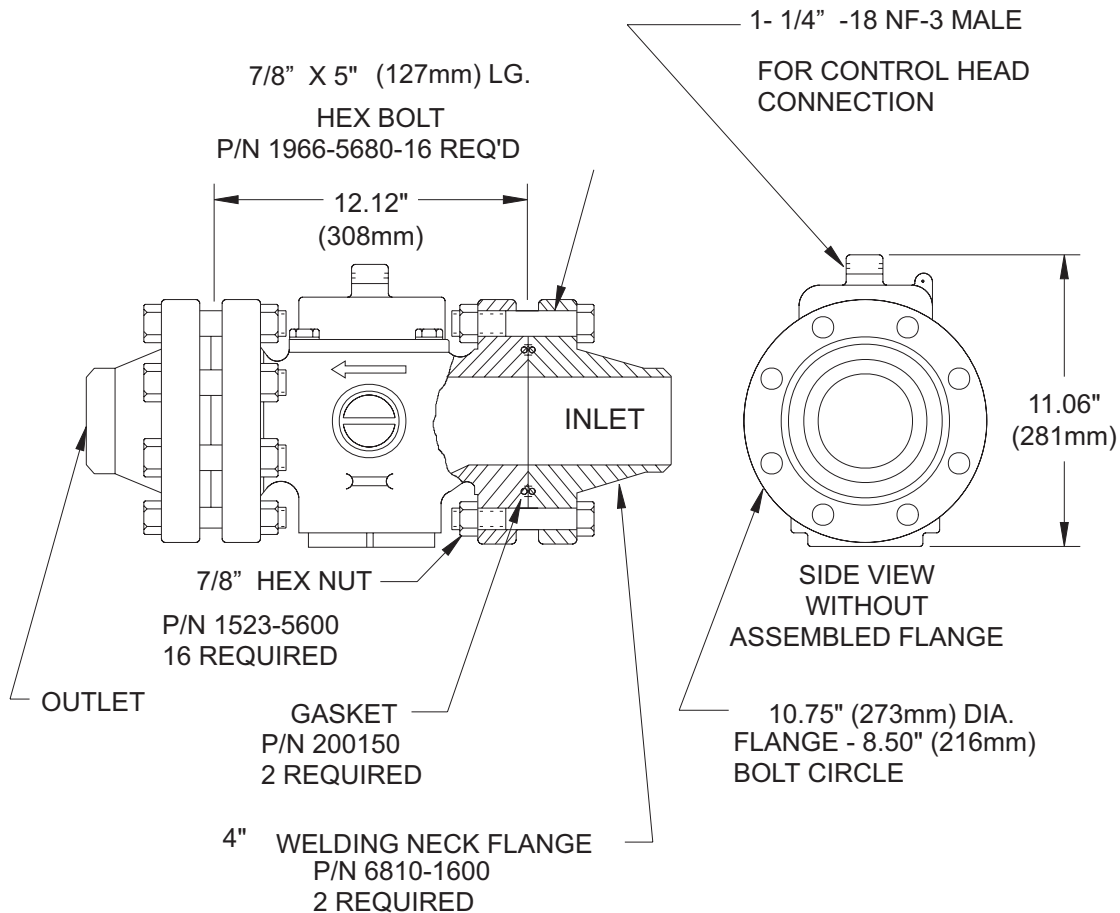

P/N: 890208

**VALVE MUST BE INSTALLED WITH ARROW POINTING  
IN DIRECTION OF FLOW.**

### MATERIALS

**VALVE BODY; BRASS**

**GASKET: IRON**

**FLANGES, BOLTS & NUTS: STEEL**

**Operating Pressure (@ 70°F): 850 PSI (58 BAR)**  
**Test Pressure: 2250 PSI (155 BAR)**  
**Burst Pressure: 6000 PSI (413 BAR)**

This literature is provided for informational purposes only. KIDDE-FENWAL, INC. assumes no responsibility for the product's suitability for a particular application. The product must be properly applied to perform as described herein.

If you need more information on this product, or if you have a question, contact KIDDE-FENWAL, INC., Ashland, MA 01721. (508) 881-2000.

**KIDDE®**  
**Fire Systems**

KIDDE-FENWAL, INC.  
400 MAIN STREET, ASHLAND, MA 01721  
TEL: (508) 881-2000 FAX: (508) 881-8920