

# CO<sub>2</sub> Operation Detail

Effective: April 1999

K-81-1061

## Assembly of Plain Nut Discharge Head to Type "I" Cylinder Valve

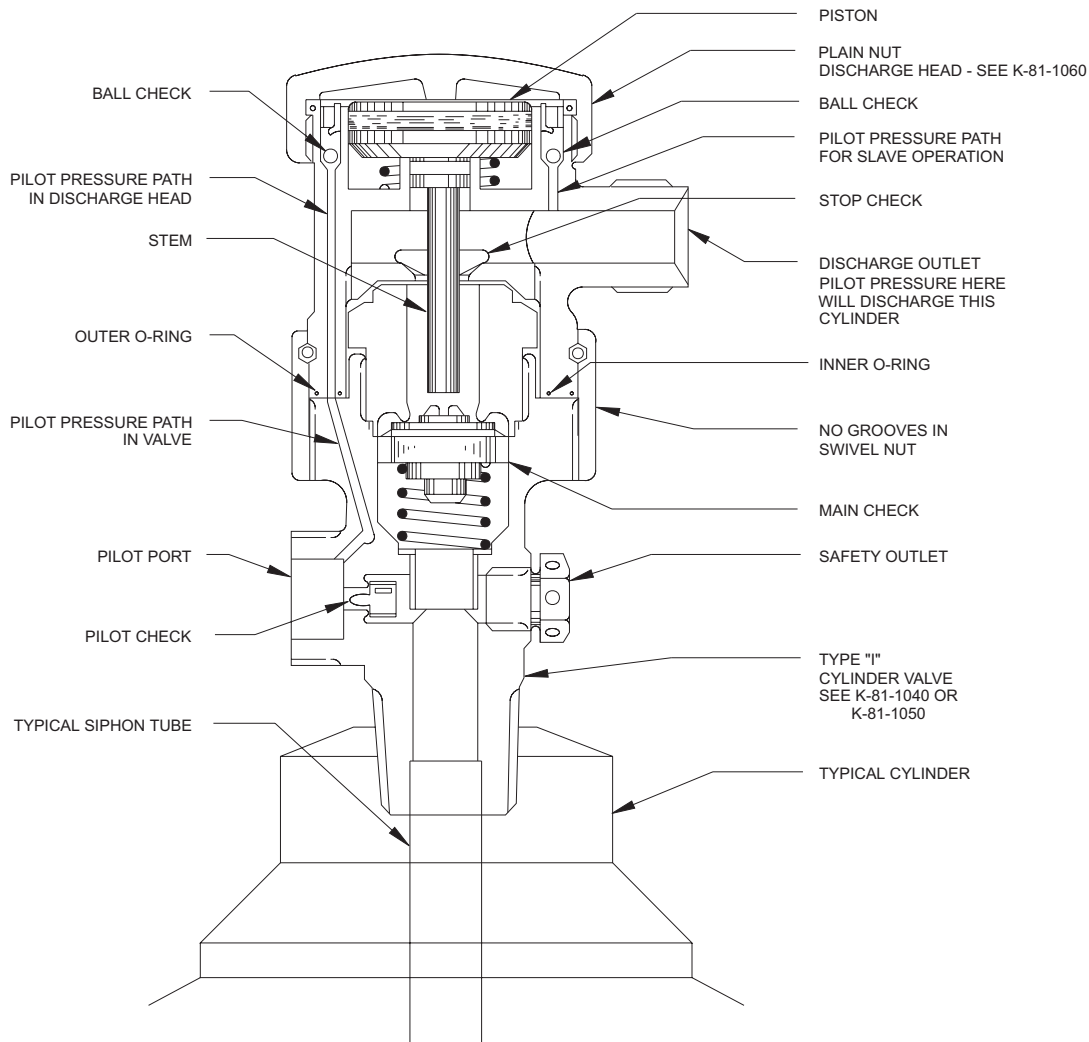

### **WARNING**

**NEVER CONNECT DISCHARGE HEAD TO CYLINDER VALVE WITHOUT FLEX LOOP ATTACHED TO DISCHARGE OUTLET AND CONNECTED TO SYSTEM PIPING AND THE CYLINDER IS PROPERLY SECURED. ARRANGEMENT AS SHOWN IS FOR ILLUSTRATION PURPOSES ONLY.**

This literature is provided for informational purposes only. KIDDE-FENWAL, INC. assumes no responsibility for the product's suitability for a particular application. The product must be properly applied to perform as described herein.

If you need more information on this product, or if you have a question, contact KIDDE-FENWAL, INC., Ashland, MA 01721. (508) 881-2000.

K-81-1061 4/99 ©1999 Kidde-Fenwal, Inc. Printed in U.S.A.

**PRESSURE RATING:**  
2400 PSIG TO 2800 PSIG (165 BAR TO 193 BAR)

**KIDDE®**  
**Fire Systems**

KIDDE-FENWAL, INC.  
400 MAIN STREET, ASHLAND, MA 01721  
TEL: (508) 881-2000 FAX: (508) 881-8920