Content

Section 1

Overview 1-1

- 1.1 SK-6324 Description 1-1
- 1.2 How to Contact Silent Knight 1-1

Section 2

Agency Requirements 2-1

- 2.1 FCC Warning 2-1
- 2.2 Underwriters Laboratories (UL) 2-1
 - 2.2.1 Requirements for All Installations 2-1
 - 2.2.2 Requirements for Local Protected Fire Alarm Systems 2-1

Section 3

Before You Begin Installing 3-1

- 3.1 What's in the Box? 3-1
- 3.2 Optional Accessories 3-2
- 3.3 SK-6324 Board Layout 3-3
- 3.4 Electrical Specifications 3-4
- 3.5 Environmental Specifications 3-4
- 3.6 Mounting the SK-6324 3-5
- 3.7 Assembly 3-6
- 3.8 Wiring Specifications 3-7
- 3.9 Calculating Current Draw and Standby Battery 3-8
 - 3.9.1 Worksheet Requirements 3-8
 - Filling in the Current Draw Worksheet, Table 3-6 (Section 3.9.3) 3-8
 - 3.9.2 Maximum Battery Standby Load 3-8
 - 3.9.3 Current Draw Worksheet 3-9

Section 4

Hardware Installation 4-1

- 4.1 AC Power 4-1
- 4.2 Battery Connection 4-2
- 4.3 Initiation Circuit Installation 4-3
 - 4.3.1 Contact Wiring 4-3
 - 4.3.2 Two-Wire Smoke Detector Wiring 4-3
 - 4.3.3 Four-Wire Smoke Detector 4-4
 - 4.3.4 Notification Circuit Installation 4-6
- 4.4 Alarm and Trouble Relays 4-6
- 4.5 Auxiliary Power Circuit 4-6
- 4.6 Door Release Wiring 4-7

4.7	Optional Accessories Installation	4-8
4.7.1	Wiring Expansion Devices To the Control Panel	4-8
4.8	SK-2866 LED Annunciator Installation	4-9
4.8.1	Electrical Specifications	4-9
4.8.2	Wiring the SK-2866 to the SK-6324 Control Panel	4-9
4.8.3	Setting the SK-2866's Address	4-10
4.8.4	Mounting the SK-2866	4-10
4.9	SK-2880 Installation	4-12
4.9.1	SK-2880 Specifications	4-12
4.9.2	Connecting the SK-2880 to the Control Panel	4-13
4.9.3	Setting the SK-2880 Address	4-13
4.9.4	Open Collector Outputs (P1, P2, and P3)	4-15
4.9.5	Wiring SK-2880 Open Collector Outputs	4-17
4.9.6	SK-2880 Input Switches and Relay Wiring	4-17
4.9.7	Mounting the SK-2880	4-18

Section 5

System Configuration 5-1

Section 6

System Operation 6-1

6.1	Meaning of LEDs	6-1
6.2	Operation Keys (Switches)	6-3

Appendix A

Compatible Devices A-1

A.1	Smoke Detectors	A-1
A.1.1	Enhanced Mode	A-1
A.1.2	Two-Wire Smoke Detectors	A-2
	Four-Wire Smoke Detectors	A-3
A.2	Notification Appliances	A-4
	General Terms and Conditions	13
	Repair and RA Procedure	13
	Advanced Replacement Policy	13
	Limited Warranty	14

Section 1

Overview

1.1 SK-6324 Description

The Model SK-6324 is a four zone, 24-volt fire control panel having the following features:

- Six Class B Zone inputs.
- 2.5 amp power supply.
- Three notification circuits rated at 2.5 amp max.
- Dedicated alarm and trouble relays.
- Auxiliary power output (.5 amp max.) for powering special applications, such as door holders.
- Enhanced Verification Mode, a built-in feature that distinguishes two-wire smoke detectors from pull stations.
- Housed in a 12.75"W x 15"H x 3.25"D metal cabinet.
- Cabinet supports two 7.0 AH backup batteries.

1.2 How to Contact Silent Knight

If you have a question or encounter a problem not covered in this manual, contact Silent Knight Technical Support at 800-328-0103 (or 612-493-6455). To order parts, contact Silent Knight Sales at 800-446-6444 (or 612-493-6435).

Section 2

Agency Requirements

2.1 FCC Warning

This device has been verified to comply with FCC Rules Part 15. Operation is subject to the two following conditions: (1) This device may not cause radio interference, and (2) This device must accept any interference received, including interference that may cause undesired operation.

2.2 Underwriters Laboratories (UL)

The SK-6324 is UL listed as a control unit for use in NFPA 72 systems. If the SK-6324 and its accessories are to be used as part of a UL installation, carefully read the UL requirements in this section. For more information on NFPA 72 standards, refer to the *NFPA National Fire Alarm Code, 1996 Edition*.

2.2.1 Requirements for All Installations

General requirements are described in this section. When installing an individual device, refer to the specific section of the manual for additional requirements.

1. All field wiring must be installed in accordance with NFPA 70 National Electric Code.
2. Use UL listed smoke detectors and notification appliances compatible with the SK-6324 from those specified in the Appendix to this manual.
3. If you are using the smoke verification feature:
 - Do not use smoke detectors with built-in alarm verification.
 - Select "Enhanced Mode" if the installation includes pull stations or water flow switches.
4. A full system checkout must be performed any time the panel is programmed.
5. UL installations using Class B wiring require the use of a Model 7628 EOL resistor assembly.

2.2.2 Requirements for Local Protected Fire Alarm Systems

At least one UL listed supervised notification appliance must be used.

Section 3

Before You Begin Installing

3.1 What's in the Box?

The Model SK-6324 ships with the following hardware:

Table 3-1: Contents of Shipping Box

Main Part	Containing		Model Number
	Part	Quantity/Item	
1 Cabinet			122509
	Panel Bag	1 Control Board	063240
		1 Installation Manual	151117
	Hardware Bag P/N 7648	2 #8 Screws	119152
		2 #8 Nuts	119538
		3 Self-tapping Screws	119296
		1 Earth Ground Wire	140668
		1 Eight Inch Tie Wrap	120504
		1 Battery Wire Harness	130420
	1 battery Jumper	140694	
1 Transformer	120 Vrms @ 60Hz		115061
	or a		
	230 Vrms at 50Hz		115031
1 Viewing Bezel		122558	
6 End-of-line Resistors		111682	

Note: See Section 3.7 for assembly instructions.

3.2 Optional Accessories

Table 3-2 is a list of optional accessories that can be used with the Model SK-6324 Fire Control Panel.

Table 3-2: Option Accessories for the SK-6324

Model Number	Name	Description
SK-2880	Input/Output (I/O) Module	Used to drive customized annunciators and interface devices.
SK-2866	LED Annunciator	Remote LED annunciator with Silence and Reset keyswitch inputs.
SK-2104	Dialer	Used to communicate alarms, trouble and supervisories to central station. Offers 5 different reporting formats 3/1, 4/2, BFSK, SIA, and Contact ID.
7628	UL listed End-of-line (EOL) Resistor.	EOL resistor required for UL installations.

3.3 SK-6324 Board Layout

Figure 3-1 shows the SK-6324 circuit board including location of terminals, connectors, dip switches, and LEDs.

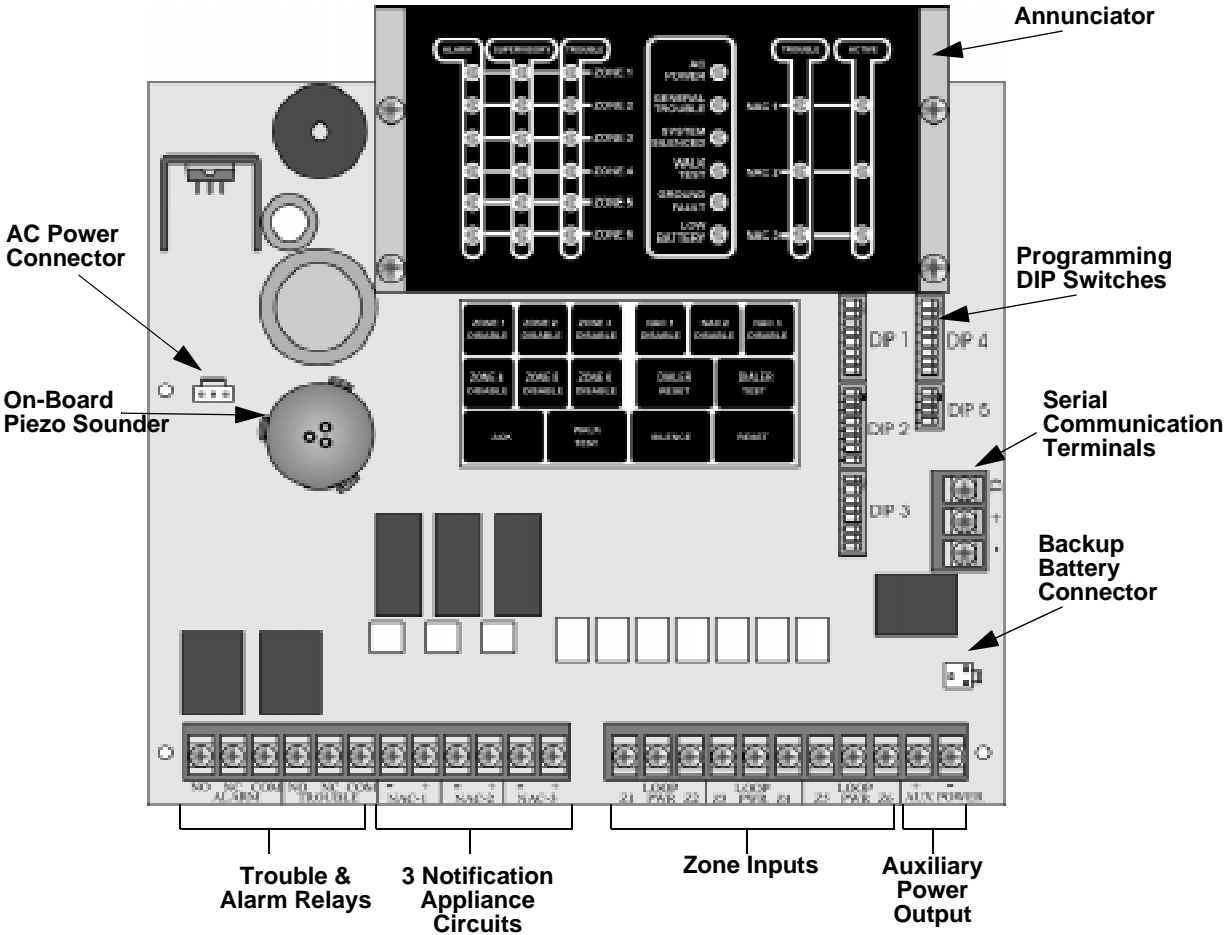

Figure 3-1 Model SK-6324 Layout

3.4 Electrical Specifications

Table 3-3: Electrical Specifications

Circuit	Rating
Primary AC	*120 Vrms at 60 Hz, or 230 Vrms at 50 Hz @ 1.5 Amps
Total External DC Load	2.5A @ 24 VDC
+24V Auxiliary Power	24 VDC, 0.5 A max.
Trouble & Alarm Relays	2.5 A @ 30 VDC resistive
Notification Appliance Power	24 VDC, 2.5 A max.
Smoke Detector Power	24 VDC, 1.0 A max.
Battery Charging Voltage	27.3 VDC
Maximum Battery Charging Current	750 mA
Minimum Low Battery Detect	20.4 V
Minimum Low AC Detect	100 Vrms at 60 Hz, full load

*Note: * When ordering, specify your voltage requirements.*

3.5 Environmental Specifications

Table 3-4: Environmental Specifications

Storage Temperature:	-4° - 167° F (-20 - 75° C)
Operating Temperature:	32° - 120° F (0° - 49° C)
Humidity:	10 - 85% non-condensing

It is important to protect the SK-6324 control panel from water. To prevent water damage, the following conditions should be AVOIDED when mounting the units:

- Do not mount directly on exterior walls, especially masonry walls (condensation)
- Do not mount directly on exterior walls below grade (condensation)
- Protect from plumbing leaks
- Protect from splash caused by sprinkler system inspection ports
- Do not mount in areas with humidity-generating equipment (such as dryers, production machinery)

3.6 Mounting the SK-6324

Read the environmental specifications in Section 3.5 before mounting the cabinet.

The panel should be accessible to main drop wiring runs. It should be mounted as close to the center of the building as possible and located within a secured area, but should be accessible for testing and service. End-users responsible for maintaining the panel should be able to hear alarms and troubles. When selecting a location, keep in mind that the panel itself is the main source of alarm and trouble annunciation.

Mount the cabinet so it is firmly secured to the wall surface. When mounting the cabinet on concrete, especially when moisture is expected, attach a piece of 3/4-inch plywood to the concrete surface and then attach the cabinet to the plywood. Also mount any other modules to the plywood.

Follow these steps to mount the control panel cabinet:

1. Place the cabinet on the mounting surface, level the cabinet and mark the top two mounting holes.
2. Screw the top two mount screws about 3/4 of the way into the mounting surface.
3. Hang the control panel cabinet on the top mounting screws through the top mounting screw keyholes.

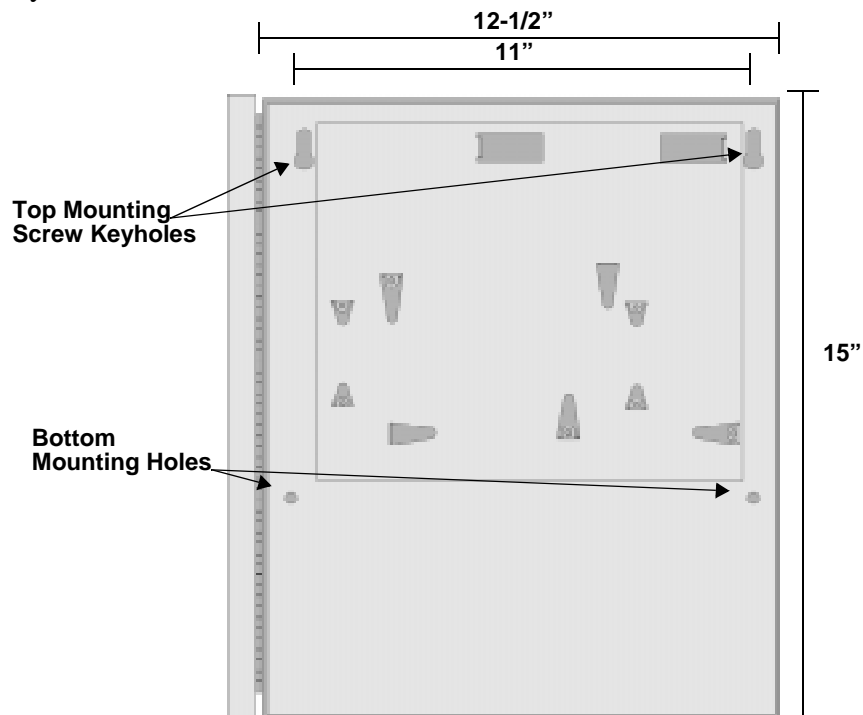

Figure 3-2 Cabinet Mounting Holes

4. Insert the bottom two mounting screws into the cabinet's bottom mounting holes.
5. Tighten all four mounting screws until the cabinet is properly secured.
6. Insert all cabinet components. See Section 3.7.

3.7 Assembly

The components listed in Table 3-1 are all packed with in the cabinet and require some assembly. Follow these steps to assemble the components inside the cabinet:

1. Remove keys from small manila envelope taped to the top of the cabinet.
2. Unlock the cabinet door.
3. Remove the packing material and the SK-6324 components.
4. Snap the bezel into the opening in the front of the cabinet. See Figure 3-3.

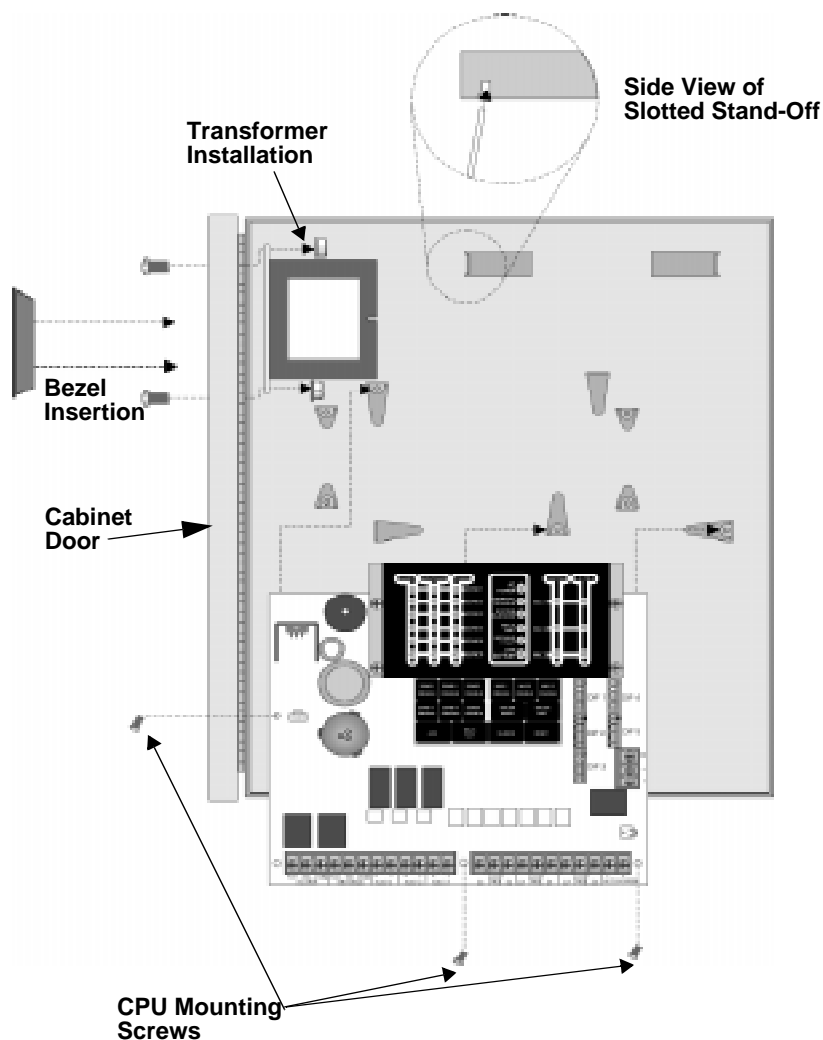

Figure 3-3 Assembly Diagram for the SK-6324

Note: The bezel will fit in only one way.

5. With the two #8 Screws and the two #8 nuts (with built in washers), mount the transformer in the holes in the upper left hand corner of the cabinet. See Figure 3-3.
6. With the three Self-trapping screws mount the control board on the cabinet stand-offs.

Note: See Section 4 for transformer connections and battery connections.

3.8 Wiring Specifications

Induced noise (transfer of electrical energy from one wire to another) can cause false alarms or interfere with control panel operation in other ways.

To avoid induced noise, follow these guidelines:

- Isolate input wiring from high current output and power wiring. Do not pull one multi-conductor cable for the entire panel. Instead, separate the wiring as follows:

High current input/output: AC power and notification device wiring

Low current input/output: Annunciator and zone loop wiring

- Do not pull wires from different groups through the same conduit. If you must run them together, do so for as short a distance as possible or use shielded cable. Connect the shield to circuit ground at the panel. You must route high and low voltages separately.
- Route the wiring within the cabinet around the perimeter of the cabinet. It should not cross the printed circuit board where it could induce noise into the sensitive microelectronics or pick up unwanted RF noise from the high speed circuits. See Figure 3-4 for an example.
- High frequency noise, such as that produced by the inductive reactance of a speaker or bell, can also be reduced by running the wire through ferrite shield beads or by wrapping it around a ferrite toroid.

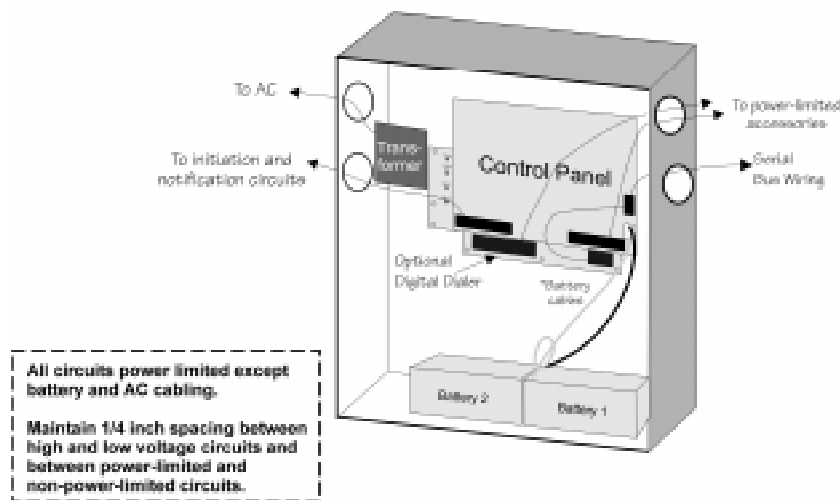

Figure 3-4 Wire Routing Example

3.9 Calculating Current Draw and Standby Battery

This section is for helping you determine the current draw and standby battery needs for your installation.

3.9.1 Worksheet Requirements

The following steps must be taken when determining SK-6324 current draw and standby battery requirements.

Filling in the Current Draw Worksheet, Table 3-6 (Section 3.9.3)

1. For the SK-6324, the worst case current draw is listed for the panel and is recorded in the table at Line A.
2. Add up the current draw for all smoke detectors and record in the table at Line B.
3. Add up all notification appliance loads and record in the table at Line C.
4. Any additional devices should be recorded at Line D.
5. Make sure that the alarm current without the panel (Lines B-D) does not exceed 2.5 A. The total alarm current (including the panel, Lines A-D) should not exceed 2.75 A.
6. Complete the remaining instructions in Table 3-6 for determining battery size requirements.

3.9.2 Maximum Battery Standby Load

Table 3-5 shows the maximum battery standby load for the SK-6324 based on 24 hours of standby. The standby load calculations of line D in the Current Draw Calculation Worksheet (Table 3-6) must be less than the number shown in Table 3-5 for the battery size used and standby hours required.

Table 3-5: Maximum Battery Standby Load

Rechargeable Battery Size	Max. Load for 24 hrs. Standby, 5 mins. Alarm	Max. Load for 60 hrs. Standby, 5 mins. Alarm
7 AH	270 mA	110 mA

3.9.3 Current Draw Worksheet

Use this worksheet to determine current requirements during alarm/battery standby operation. (Copy this page if additional space is required.)

Table 3-6: Current Draw Calculations

Device	Number of Devices	Current per Device	Standby Current	Alarm Current
For each device, use this formula: This Column X This column = Current per number of devices				
SK-6324 Panel	1	Standby: 90 mA	90 mA	
		Alarm: 295 mA		295 mA
Current Subtotals:			90 mA	295 mA
Smoke Detectors	Refer to device manual for current ratings. See Appendix to this manual for max. # per loop.			
		Standby: mA	mA	
		Alarm: mA		mA
		Standby: mA	mA	
		Alarm: mA		mA
		Standby: mA	mA	
		Alarm: mA		mA
		Standby: mA	mA	
		Alarm: mA		mA
Current Subtotals:			mA	mA
Notification Devices	Refer to device manual for number of devices and current ratings.			
		Alarm: mA		mA
		Alarm: mA		mA
		Alarm: mA		mA
Current Subtotals:			mA	mA
Accessory Devices				
SK-2866		Standby: 35 mA	mA	
		Alarm: 85 mA		mA
SK-2880		Standby: 35 mA	mA	
		Alarm: 680 mA		mA
SK-2104		Standby: 35 mA	mA	
		Alarm: 70 mA (while dialing)		mA
Current Subtotals:			mA	mA
*Additional Devices				
		Standby: mA	mA	
		Alarm: mA		mA
		Standby: mA	mA	
		Alarm: mA		mA
Current Subtotals:			mA	mA
F	Total current rating of all devices in system (add TOTALS OF A-E) X .001:		A	A
G	Number of standby hours. (24 or 60 for NFPA 72, chapter 1, 1-5.2.5):		H	
H	Multiply lines F (standby current) and G:		Total standby AH	AH
I	Alarm sounding period in hours. (For example, 5 minutes = .0833 hours)			H
J	Multiply lines F (alarm current) and I:		Total alarm AH	AH
K	Add lines H and J. (AH = Ampere Hours)		Total AH required	AH

Note: If you are using door holders, you do not need to consider door holder current for alarm current because power is removed during that time. However, during normal operation, door holders draw current and must be included in the total standby current that can be drawn from the panel.

Note: Total standby current must not exceed maximum Battery standby load listed in Table 3-5.

4.2 Battery Connection

The SK-6324 battery charge capacity is 7.0 AH. Use two 12V batteries of the same AH rating. Determine the correct AH rating as per your current load calculation (see Table 3-6).

Wire batteries in series to produce a 24-volt equivalent. Do not parallel batteries to increase the AH rating.

Note: The SK-6324 cabinet supports two 7.0 AH batteries.

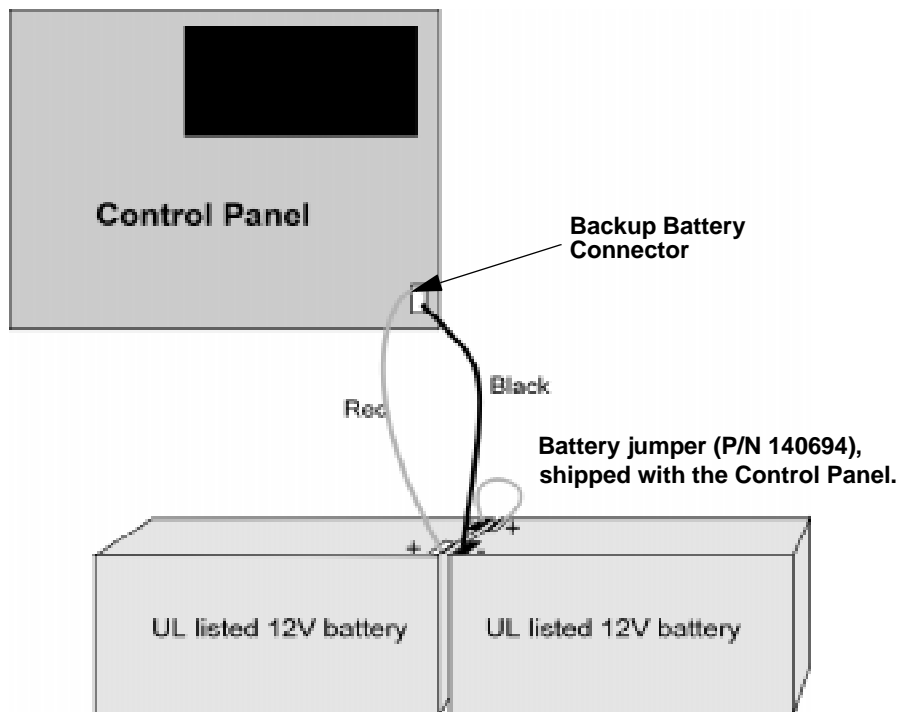

Figure 4-2 Battery Connection

4.3 Initiation Circuit Installation

4.3.1 Contact Wiring

Wire normally open contacts as shown in Figure 4-3. This is the type of wiring that would typically be used for water flow switches, heat detectors and other normally open devices.

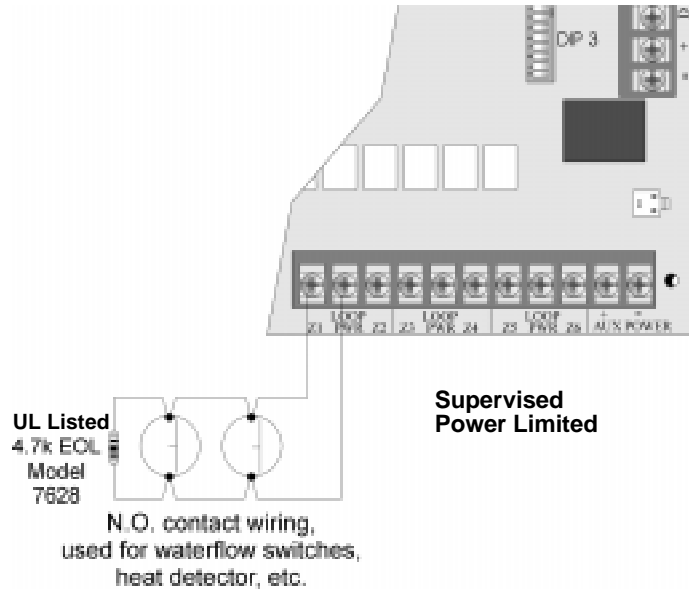

Figure 4-3 N.O. Contact Wiring

4.3.2 Two-Wire Smoke Detector Wiring

Figure 4-4 shows how to connect two-wire smoke detectors to the SK-6324 loops. The figure uses Silent Knight's SLK-24F with HSB-224 base as an example. You can use any detector that has been UL listed for compatibility with the SK-6324. Refer to the Appendix for a list of compatible devices. Refer to Section 5 for configuration options.

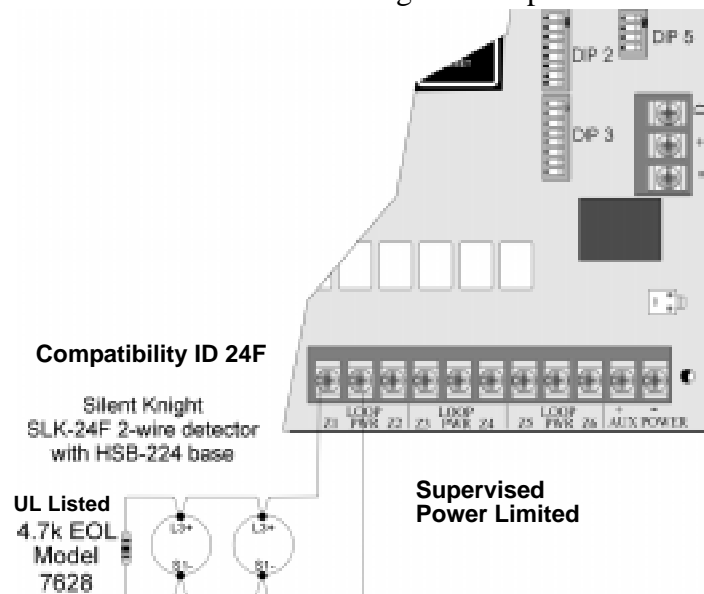

Figure 4-4 Two-Wire Smoke Detector Wiring

4.3.3 Four-Wire Smoke Detector

Figure 4-5 shows how to connect four-wire smoke detectors to the SK-6324 loops. The figure uses Silent Knight's SLK-24F with HSC-4R base as an example. You can use any UL listed device. Refer to the Appendix for a list of compatible devices. Information on selecting zone configuration options is in Section 5.

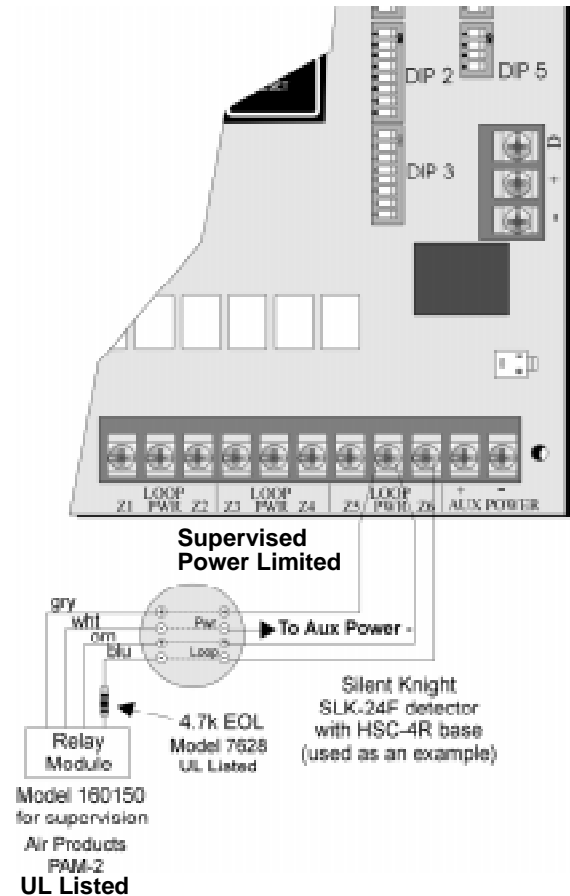

Figure 4-5 Four-Wire Smoke Detector Wiring

4.3.4 Notification Circuit Installation

Notification appliances used with the SK-6324 must be UL listed for compatibility with the SK-6324. Refer to the list in the Appendix at the end of this manual for a list of compatible devices.

For proper operation, you must use polarized notification devices with a model 7628 4.7k ohm end-of-line (EOL) resistor on each loop. Select ANSI output pattern, if desired. Output is configured as steady (continuous sound) at the factory. See Section 5 for information on changing the pattern.

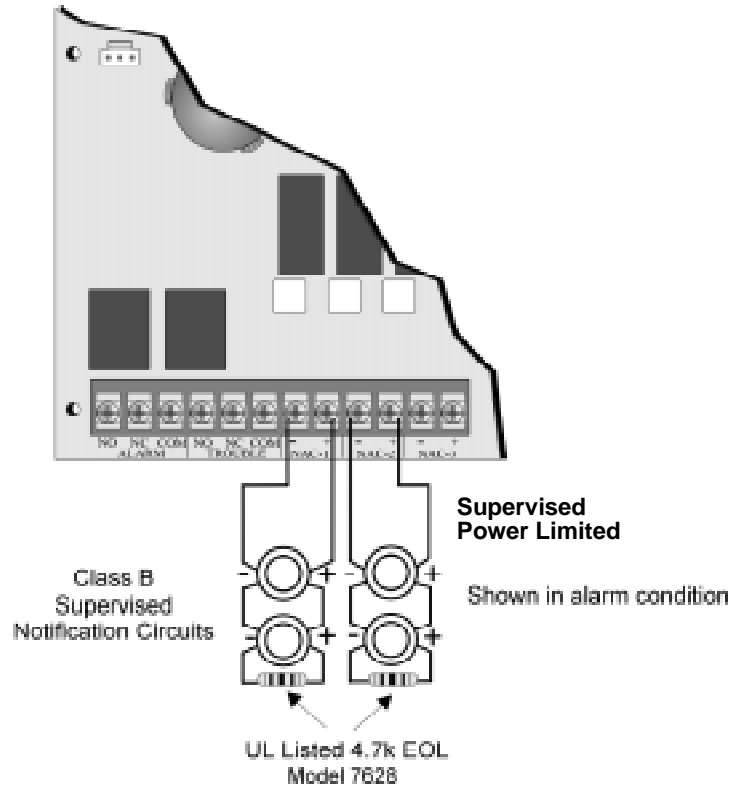

Figure 4-6 Notification Circuit Installation

4.4 Alarm and Trouble Relays

The SK-6324 has built-in relays for alarm and trouble. The alarm relay is energized during any alarm condition. The trouble relay is energized during any trouble or supervisory trouble condition. Each relay has three terminals (N.O., Common, and N.C.). Refer to Figure 3-1 for location of these terminals.

4.5 Auxiliary Power Circuit

The SK-6324 has a power limited auxiliary power circuit which can source up to .5A. The terminal is labeled "AUX PWR". Refer to Figure 3-1 for location of this terminal.

4.6 Door Release Wiring

Figure 4-7 shows how to configure a door release using an ESL DH series door holder.

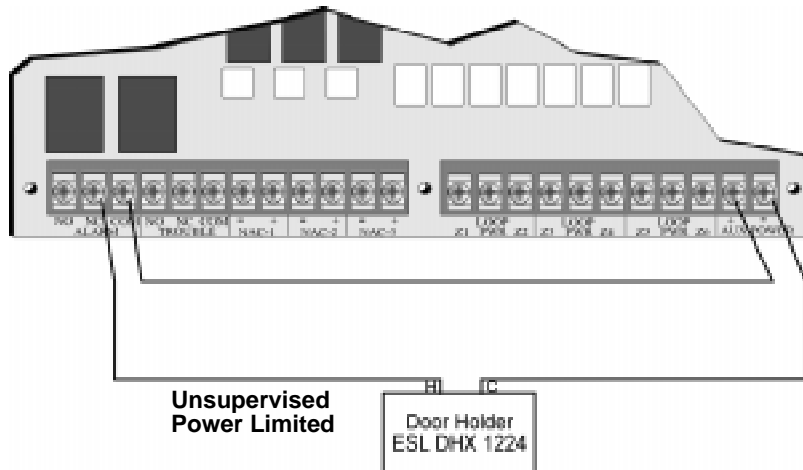

Figure 4-7 Door Release Wiring

4.7 Optional Accessories Installation

This section describes how to install the optional accessories compatible with the SK-6324 control panel. The control panel can have one SK-2104 dialer and up to four other accessory devices (any combination) connected to the serial bus.

Model Number	Name	Description
SK-2866	Remote LED Annunaiator	Remote LED annunciator with system reset and silence key switch inputs. See Section 4.8.
SK-2880	Input/Output (I/O) Module	Used to drive customized annunciators and interface devices. See Section 4.9.
SK-2104	Dialer	Used to communicate alarms, trouble and supervisories to central station. Offers 5 different reporting formats 3/1, 4/2, BFSK, SIA, and Contact ID. Note: See <i>SK-2104 Installation manual P/N 151102</i> to install this accessory.

4.7.1 Wiring Expansion Devices To the Control Panel

The control panel uses a three wire connection to all of the compatible expansion devices (see Table 3-2).

Connect all the expansion devices to the control panel as follows:

Table 4-1: Control Panel Wiring Connections

Control Panel Terminals	To Expansion Device Terminal
-	-
+	+
D (Data)	D (Data)

4.8 SK-2866 LED Annunciator Installation

The following instructions are a quick reference guide, refer to the control panel installation manual *SK-6324* (P/N 151117) for detailed system information.

4.8.1 Electrical Specifications

Table 4-2 lists the electrical specifications for the SK-2866.

Table 4-2: Electrical Specifications

Circuit		Rating
Max. Loop Resistance:	Data	50Ω
	-	50Ω
	+	50Ω
Max. Current:	Alarm:	85 mA
	Standby:	35 mA
Operating Voltage:		24 VDC

4.8.2 Wiring the SK-2866 to the SK-6324 Control Panel

Note: Installation and wiring of this device must be done in accordance with NFPA 72 and local ordinances.

Follow these steps to properly wire the SK-2866 to the SK-6324 Control Panel:

1. Remove AC power from the panel by unplugging the AC power connector from the control panel (See Section 4.1).
2. Disconnect the backup battery from the control panel (See Section 4.2).
3. Terminate the wiring as shown in Figure 4-8. See also Table 4-3.

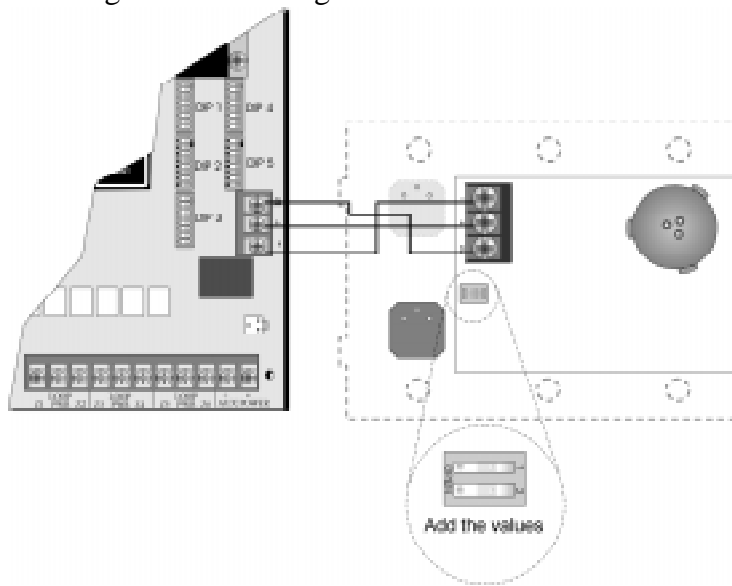

Figure 4-8 SK-2866 Connection to the SK-6324

Table 4-3: SK-2866 Wiring Connections

SK-2866 Terminals	SK-6324 Terminals
D (Data)	D (Data)
+	+
-	-

4.8.3 Setting the SK-2866's Address

The range of valid addresses is 0-3. Each device requires a unique address. Set the dip switches as shown in Table 4-4. See Figure 4-8 for dip switch location.

Table 4-4: Addresses Per Dip Switch Setting

Dip Switch	Position	Address
Both	Open (off)	0
One	Closed (on)	1
Two	Closed (on)	2
Both	Closed (on)	3

4.8.4 Mounting the SK-2866

The SK-2866 mounts in a standard 3-gang electrical box.

Follow these steps to mount the SK-2866:

1. Make sure that the SK-2866 is properly wired to the control panel. See Figure 4-8.
2. Slide the printed annunciator label into place on the SK-2866. The label fits between the LEDs and the clear plastic plate. See Figure 4-9.

3. Place the SK-2866 into the standard 3-gang electrical box. See Figure 4-9.

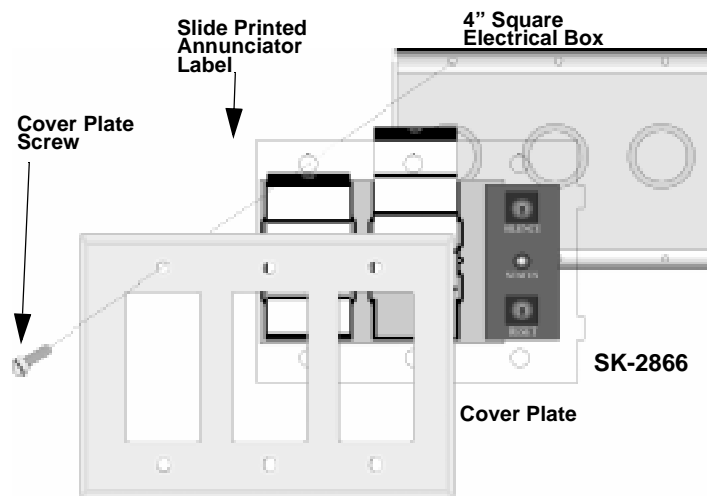

Figure 4-9 Mounting the SK-2866

4. Place the cover plate over the top of the SK-2866 and align the holes. See Figure 4-9.
5. Insert the four cover plate screws into the four screw holes on the standard 3-gang electrical box.
6. Screw the four cover plate screws into the cover plate until the cover plate fits firmly against the SK-2866 and the electrical box. Do Not over tighten.

4.9 SK-2880 Installation

The SK-2880 is an Input/Output module. The SK-2880 has 34 pre-defined open collector outputs (see Table 4-7) that can be used to drive LEDs, interface with other controls or systems, or control one of the three built-in Form C relays. See Figure 4-10, Figure 4-12 and Figure 4-13.

The SK-2880 also has two supervised inputs used for Reset and Silence. See Figure 4-13.

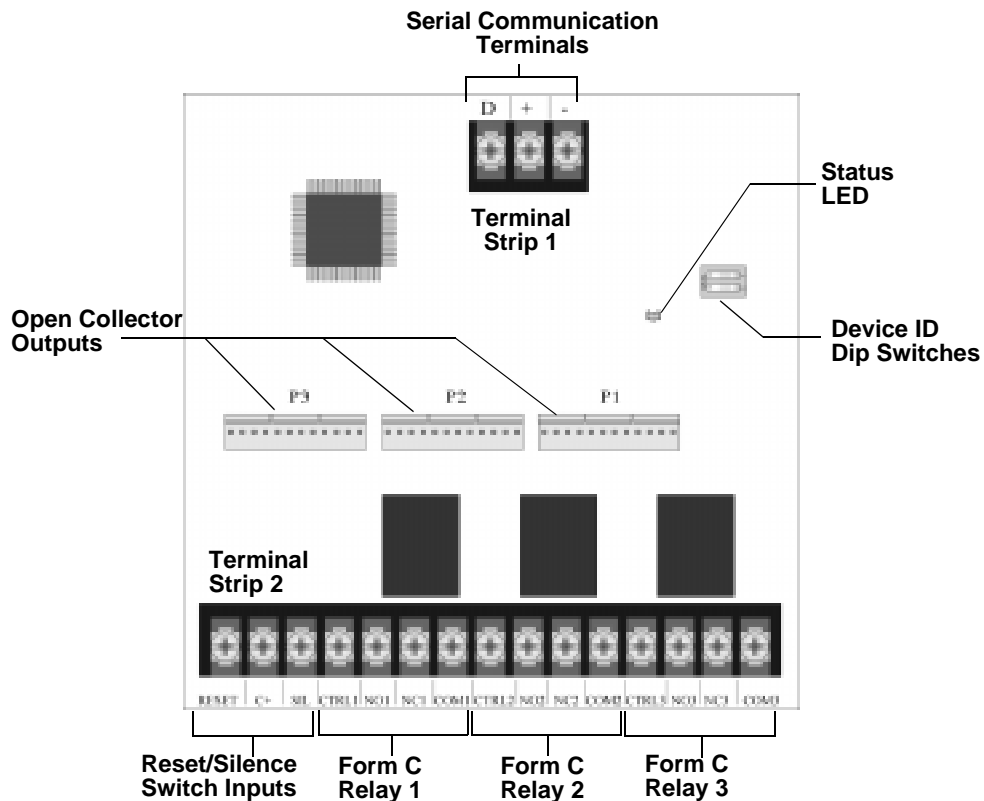

Figure 4-10 Components of the SK-2880 I/O Module

4.9.1 SK-2880 Specifications

Table 4-5: Specifications

Circuit		Rating
Max. Loop Resistance:	Data	25Ω
	-	25Ω
	+	25Ω
Max. Current:	Alarm:	35 mA
	Standby:	35 mA
	Open Collector:	20 mA each or 680 mA total.
Operating Voltage:		24 VDC
Operating Temperature:		32° - 120° F (0° - 49° C)
Form C Relays		2.5 A @ 30 VDC Resistive

Table 4-5: Specifications

Circuit		Rating
Silence/Reset Inputs	Max. Short Circuit Current:	2.8 mA

4.9.2 Connecting the SK-2880 to the Control Panel

The control panel communicates to the I/O module through the Serial Interface (see also Section 4.7.1). Figure 4-11 illustrates how to properly wire the I/O module to the Serial Interface.

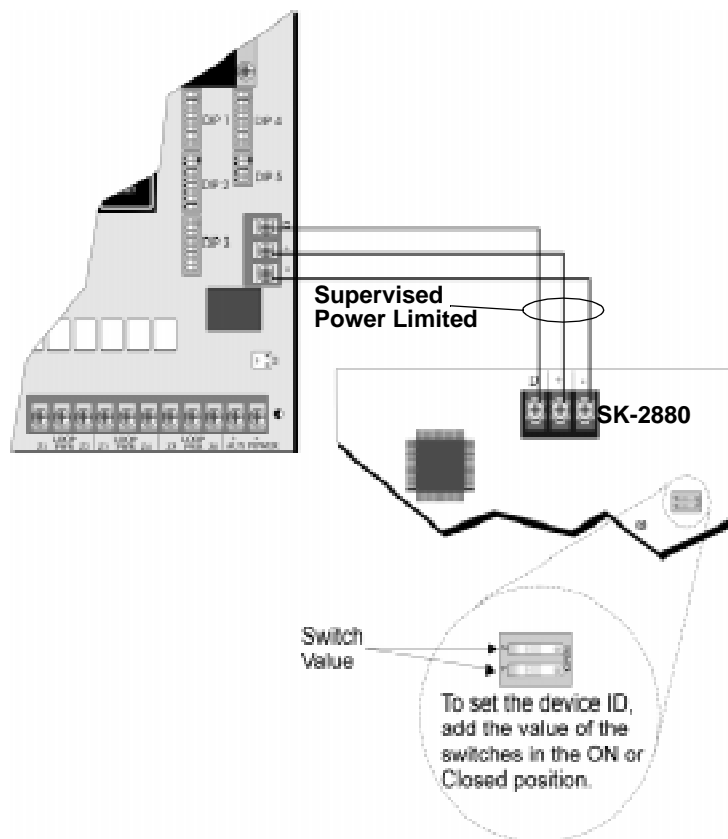

Figure 4-11 I/O Module Wiring

4.9.3 Setting the SK-2880 Address

The range of valid addresses is 0-3. Each device requires a unique address. Set the dip switches as shown in Table 4-6. See Figure 4-11 for dip switch location.

Table 4-6: SK-2880 Addresses Per Dip Switch Setting

Dip Switch	Position	Address
Both	Open (off)	0
One	Closed (on)	1
Two	Closed (on)	2
Both	Closed (on)	3

4.9.4 Open Collector Outputs (P1, P2, and P3)

Each pin on the Pin Connectors (P1, P2, and P3) have a predefined output. Table 4-7 lists the Pin Connectors and describes what each pin outputs.

Table 4-7: Pin-outs for Open Collector Outputs

Pin Connector	Pin Number	Output	Description
P1	Pin 1	Zone 1 Alarm/Supervisory	Outputs when there is an alarm or supervisory on Zone 1.
	Pin 2	Zone 1 Trouble	Outputs when a trouble condition exists on Zone 1.
	Pin 3	Zone 1 Clean-Me Trouble	Outputs when a "Clean-Me" type detector indicates a Clean-me trouble on Zone 1.
	Pin 4	Zone 2 Alarm/Supervisory	Outputs when there is an alarm or supervisory on Zone 2.
	Pin 5	Zone 2 Trouble	Outputs when a trouble condition exists on Zone 2.
	Pin 6	Zone 2 Clean-Me Trouble	Outputs when a "Clean-Me" type detector indicates a Clean-me trouble on Zone 2.
	Pin 7	Zone 3 Alarm/Supervisory	Outputs when there is an alarm or supervisory on Zone 3.
	Pin 8	Zone 3 Trouble	Outputs when a trouble condition exists on Zone 3.
	Pin 9	Zone 3 Clean-Me Trouble	Outputs when a "Clean-Me" type detector indicates a Clean-me trouble on Zone 3.
	Pin 10	Zone 4 Alarm/Supervisory	Outputs when there is an alarm or supervisory on Zone 4.
	Pin 11	Zone 4 Trouble	Outputs when a trouble condition exists on Zone 4.
	Pin 12	Zone 4 Clean-Me Trouble	Outputs when a "Clean-Me" type detector indicates a Clean-me trouble on Zone 4.
Pin 2	Pin 1	Zone 5 Alarm/Supervisory	Outputs when there is an alarm or supervisory on Zone 5.
	Pin 2	Zone 5 Trouble	Outputs when a trouble condition exists on Zone 5.
	Pin 3	Zone 5 Clean-Me Trouble	Outputs when a "Clean-Me" type detector indicates a Clean-me trouble on Zone 5.
	Pin 4	Zone 6 Alarm/Supervisory	Outputs when there is an alarm or supervisory on Zone 6.
	Pin 5	Zone 6 Trouble	Outputs when a trouble condition exists on Zone 6.
	Pin 6	Zone 6 Clean-Me Trouble	Outputs when a "Clean-Me" type detector indicates a Clean-me trouble on Zone 6.
	Pin 7	Zone 1 & 2 Pre-Alarm	Outputs when zones 1 or 2 is in alarm (not both), and cross alarm for zones 1 and 2 is enabled.
	Pin 8	Zone 3 & 4 Pre-Alarm	Outputs when zones 3 or 4 is in alarm (not both), and cross alarm for zones 3 and 4 is enabled.
	Pin 9	Zone 5 & 6 Pre-Alarm	Outputs when zones 5 or 6 is in alarm (not both), and cross alarm for zones 5 and 6 is enabled.
	Pin 10	System Status	Steady output when system is O.K. Off during a trouble, alarm or supervisory condition.
	Pin 11	+24 VDC	Positive 24 DC voltage output.
	Pin 12	GND	Circuit Ground

Table 4-7: Pin-outs for Open Collector Outputs

Pin Connector	Pin Number	Output	Description
Pin 3	Pin 1	NAC 1 Trouble	Outputs when a trouble condition exists on NAC 1.
	Pin 2	NAC 2 Trouble	Outputs when a trouble condition exists on NAC 2.
	Pin 3	NAC 3 Trouble	Outputs when a trouble condition exists on NAC 3.
	Pin 4	Dialer Trouble	Outputs when any type of trouble occurs with the dialer, such as, no line voltage or a communication failure.
	Pin 5	Expander Trouble	Outputs when one of the Serial Devices connected to the control panel is in trouble.
	Pin 6	Alarm Silenced	Outputs when an alarm has been silenced.
	Pin 7	Low AC	Outputs if the control panel loses AC power or AC power drops below the control panels low AC threshold.
	Pin 8	Low Battery	Outputs when the backup battery voltage drops below 20.4 VDC.
	Pin 9	Ground Fault	Outputs when the control panel detects a ground fault condition.
	Pin 10	Walk Test Active	Outputs when the control panel is in walk test mode.
	Pin 11	Piezo Output	Outputs correspond to any trouble condition output from the control panel.
	Pin 12	Local Trouble	Outputs if the end-of-line resistor on the Reset or silence inputs not detected or if a serial communication problem occurs between this device and the control panel.

4.9.5 Wiring SK-2880 Open Collector Outputs

Figure 4-12 illustrates examples of how to configure the open collector outputs on the I/O module for your uses.

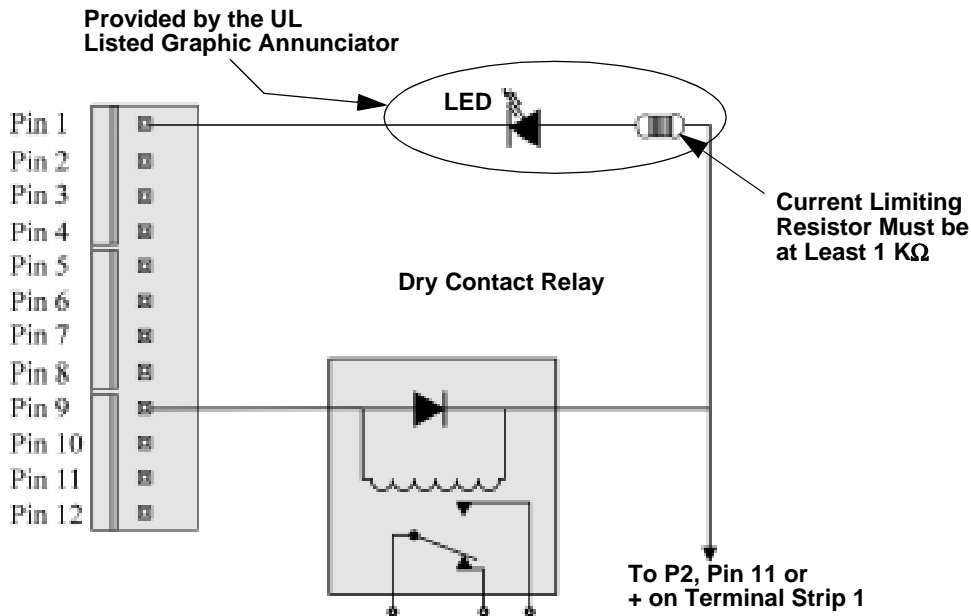

Figure 4-12 Output Configurations

4.9.6 SK-2880 Input Switches and Relay Wiring

This section describes the components of terminal strip 2 (see Figure 4-10) on the SK-2880. Terminal strip 2 provides two input switches (Reset & Silence) and three Form C relay. Figure 4-13 illustrates how to configure the inputs switches and the Form C Relays.

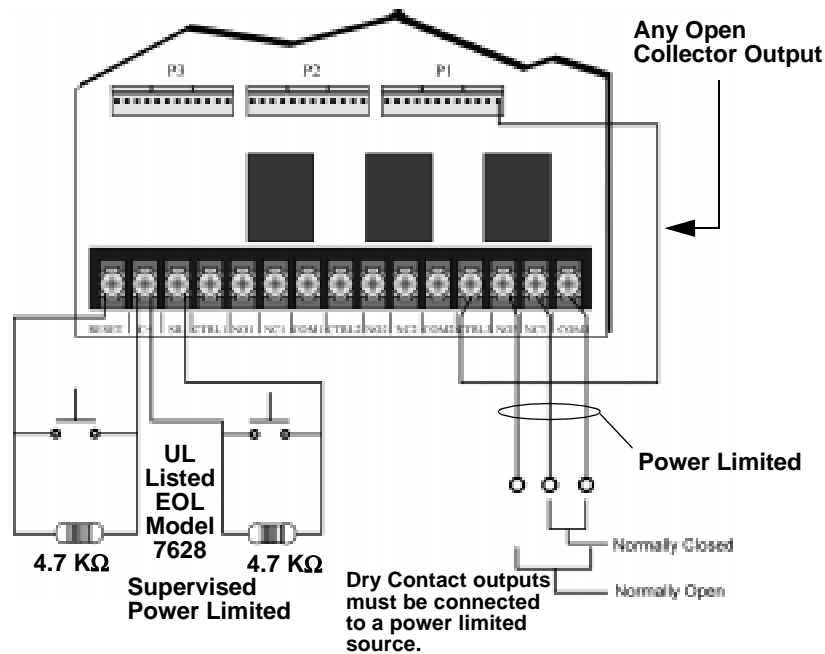

Figure 4-13 Wiring Examples for Input Switches and Form C Relays

Note: Reset and Silence switches must be UL recognized switches. Reset and Silence switches must be in the same room as the UL Listed Graphic Annunciator.

4.9.7 Mounting the SK-2880

The I/O module must be mounted by itself in a UL Listed (for Fire Protective Signal) accessory cabinet.

Follow these steps to mount the SK-2880:

1. Remove the SK-2880's cover. A small screw driver can be used.
2. Remove the SK-2880 circuit board from the base by pushing outward on the base retaining tabs and lift the circuit board out. See Figure 4-14.

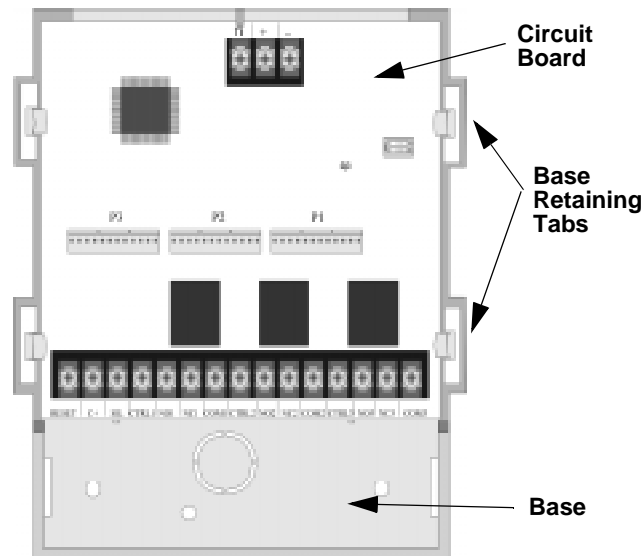

Figure 4-14 Circuit Board and Plastic Base Components

3. Mount the plastic base in a UL listed enclosure using any of the mounting holes in the plastic base. See Figure 4-15 for locations of base mounting holes.

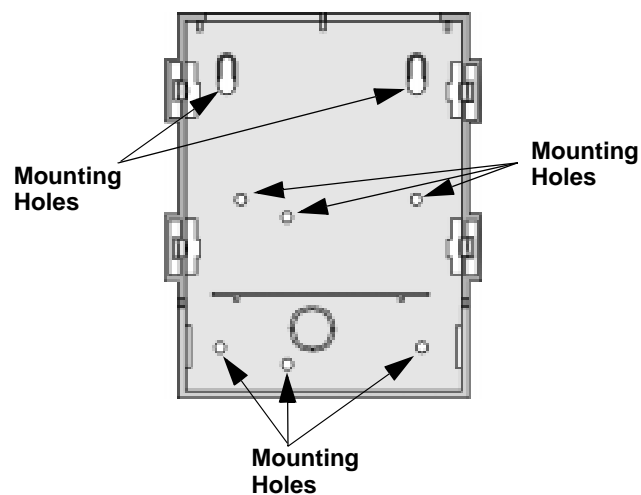

Figure 4-15 Base Mounting Holes

4. Replace the SK-2880 circuit board back into the base.
5. Verify the proper wire termination and then snap the I/O module cover in place.

Section 5

System Configuration

To configure the SK-6324 system set the dipswitch that controls the option you want to select. The following chart shows how to program the dipswitches that control system, zone, and notification appliance operation. Refer to Figure 3-1 for location of the dipswitches.

Important!

When you change a dipswitch, be sure to power down the panel. Dipswitch changes will be recognized on power up only.

Table 5-1: DIP Switch Programming

Options	Dip Switch Number	Feature	Switch Number	Comments	
Zone 1	1	Enhanced Mode On	1 On	Enhanced mode. Use when both pull stations and detectors will be used in the same zone.	
		Enhanced Mode Off	1 Off	Normal mode. Use when 2- or 4-wire smoke detectors and smoke verification are used in the same zone.	
		Alarm Verification On	2 On	Alarm Verification Note: Do not use with smoke detectors that have verification built-in.	
		Alarm Verification Off	2 Off	No verification	
		Zone Types	Fire Zone	3 Off	
				4 Off	
			Supervisory Zone	3 On	
				4 Off	
			Water Flow Zone No Delay	3 Off	
				4 On	
Water Flow Zone With Delay	3 On	Refer to "General Options" to program the Water Flow delay time.			
	4 On				

Table 5-1: DIP Switch Programming

Options	Dip Switch Number	Feature	Switch Number	Comments	
Zone 2	1	Enhanced Mode On	5 On	Enhanced mode. Use when both pull stations and detectors will be used in the same zone.	
		Enhanced Mode Off	5 Off	Normal mode. Use when 2- or 4-wire smoke detectors and smoke verification are used in the same zone.	
		Alarm Verification On	6 On	Alarm Verification Note: Do not use with smoke detectors that have verification built-in.	
		Alarm Verification Off	6 Off	No verification	
		Zone Types	Fire Zone	7 Off	
				8 Off	
			Supervisory Zone	7 On	
				8 Off	
			Water Flow Zone No Delay	7 Off	
				8 On	
Water Flow Zone With Delay	7 On		Refer to "General Options" to program the Water Flow delay time.		
	8 On				
Zone 3	2	Enhanced Mode On	1 On	Enhanced mode. Use when both pull stations and detectors will be used in the same zone.	
		Enhanced Mode Off	1 Off	Normal mode. Use when 2- or 4-wire smoke detectors and smoke verification are used in the same zone.	
		Alarm Verification On	2 On	Alarm Verification Note: Do not use with smoke detectors that have verification built-in.	
		Alarm Verification Off	2 Off	No verification	
		Zone Types	Fire Zone	3 Off	
				4 Off	
			Supervisory Zone	3 On	
				4 Off	
			Water Flow Zone No Delay	3 Off	
				4 On	
Water Flow Zone With Delay	3 On		Refer to "General Options" to program the Water Flow delay time.		
	4 On				

Table 5-1: DIP Switch Programming

Options	Dip Switch Number	Feature	Switch Number	Comments	
Zone 4	2	Enhanced Mode On	5 On	Enhanced mode. Use when both pull stations and detectors will be used in the same zone.	
		Enhanced Mode Off	5 Off	Normal mode. Use when 2- or 4-wire smoke detectors and smoke verification are used in the same zone.	
		Alarm Verification On	6 On	Alarm Verification Note: Do not use with smoke detectors that have verification built-in.	
		Alarm Verification Off	6 Off	No verification	
		Zone Types	Fire Zone	7 Off	
				8 Off	
			Supervisory Zone	7 On	
				8 Off	
		Water Flow Zone No Delay	7 Off		
			8 On		
Water Flow Zone With Delay	7 On	Refer to "General Options" to program the Water Flow delay time.			
		8 On			
Zone 5	3	Enhanced Mode On	1 On	Enhanced mode. Use when both pull stations and detectors will be used in the same zone.	
		Enhanced Mode Off	1 Off	Normal mode. Use when 2- or 4-wire smoke detectors and smoke verification are used in the same zone.	
		Alarm Verification On	2 On	Alarm Verification Note: Do not use with smoke detectors that have verification built-in.	
		Alarm Verification Off	2 Off	No verification	
		Zone Types	Fire Zone	3 Off	
				4 Off	
			Supervisory Zone	3 On	
				4 Off	
		Water Flow Zone No Delay	3 Off		
			4 On		
Water Flow Zone With Delay	3 On	Refer to "General Options" to program the Water Flow delay time.			
		4 On			

Table 5-1: DIP Switch Programming

Options	Dip Switch Number	Feature	Switch Number	Comments	
Zone 6	3	Enhanced Mode On	5 On	Enhanced mode. Use when both pull stations and detectors will be used in the same zone.	
		Enhanced Mode Off	5 Off	Normal mode. Use when 2- or 4-wire smoke detectors and smoke verification are used in the same zone.	
		Alarm Verification On	6 On	Alarm Verification Note: Do not use with smoke detectors that have verification built-in.	
		Alarm Verification Off	6 Off	No verification	
		Zone Types	Fire Zone	7 Off	
				8 Off	
			Supervisory Zone	7 On	
				8 Off	
			Water Flow Zone No Delay	7 Off	
				8 On	
Water Flow Zone With Delay	7 On	Refer to "General Options" to program the Water Flow delay time.			
		8 On			
Output Options	4	NAC 1 Silence	1 On		
		NAC 1 Non-Silencing	1 Off		
		NAC 1 ANSI	2 On		
		NAC 1 Steady	2 Off		
		NAC 2 Silence	3 On		
		NAC 2 Non-Silencing	3 Off		
		NAC 2 ANSI	4 On		
		NAC 2 Steady	4 Off		
		NAC 3 Silence	5 On		
		NAC 3 Non-Silencing	5 Off		
		NAC 3 ANSI	6 On		
		NAC 3 Steady	6 Off		
		Annunciator Installed	7 On		
		No Annunciator Installed	7 Off		
Dialer Installed	8 On				
No Dialer Installed	8 Off				
General Options	5	Water Flow Delay 90 Seconds	1 On		
		Water Flow Delay 45 Seconds	1 Off		
		NAC circuits unsilenceable for water flow alarms	2 On		
		NAC circuits silenceable for water flow alarms	2 Off		
		NAC 3 Pre-Alarm Enabled	3 On	Note: If this feature turned on the NAC 3 will not sound for alarms.	
		NAC 3 Pre-Alarm Disabled	3 Off		
		NAC 3 Sounds for Supervisories	4 On	Note: If this feature turned on the NAC 3 will not sound for alarms.	
		NAC 3 No Sound for Supervisories	4 Off		

Section 6

System Operation

The annunciator on the SK-6324 board is used for all system operation. It contains the switches (Figure 6-2) for enabling silencing, resetting, and so on. The LEDs (Figure 6-1) that indicate system status are also located on the annunciator.

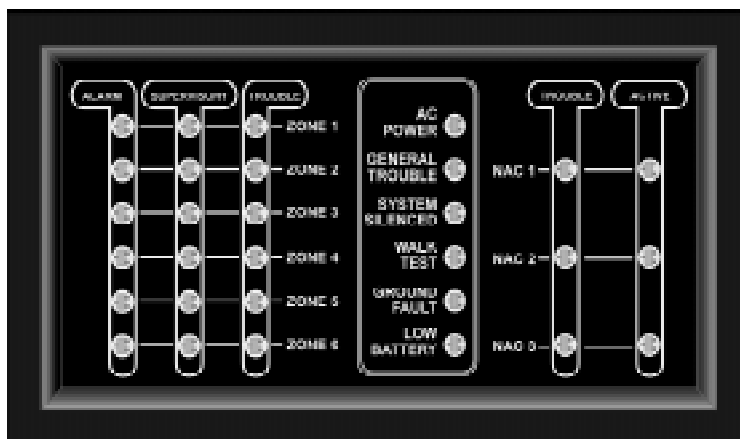

Figure 6-1 On-Board Annunciator

6.1 Meaning of LEDs

The chart below explains the meaning of LEDs on the system board.

Table 6-1: Meaning of LEDs

LED (Color)	Function	Comments
AC POWER (green)	ON = Good AC OFF = Low AC trouble condition and it was acknowledged FLASHING = Unacknowledged AC Low trouble condition	If flashing press the ACK button to acknowledged the condition.
GENERAL TROUBLE (yellow)	ON = System trouble OFF = System OK FLASHING = At least one serial device is in trouble DOUBLE FLASHING = Two types of serial devices are in trouble.	
SYSTEM SILENCED (yellow)	ON = System audible output has been silenced OFF = Nothing silenced FLASHING = Partially silenced	Audible trouble activations will clear automatically when the condition resets. Audible alarm signals have to be manually reset. Note: Silencing an alarm will cause a general trouble condition.

Table 6-1: Meaning of LEDs

LED (Color)		Function	Comments
WALK TEST (yellow)		ON = Walk test is in progress OFF = Walk test is off. FLASHING = Walk test is on and at least one zone is not ready	Allow approximately 47 seconds between detector tests. In walk test when a detector is tripped it will cause an alarm for two seconds, then the control panel will drop power to the loop for seven seconds to reset the detector. Then an additional 38 seconds is needed to restore the detector. If verification is used the time between detector test will be about 2 minutes and 30 seconds.
GROUND FAULT (yellow)		ON = Ground fault condition exists and was acknowledged OFF = No fault FLASHING = A unacknowledged ground fault condition detected	If flashing press the ACK button to acknowledged the condition.
LOW BATTERY (yellow)		ON = Battery low condition that has been acknowledged OFF = Good battery condition FLASHING = An unacknowledged battery low condition exists	If flashing press the ACK button to acknowledged the condition.
ZONE 1 Through ZONE 6	ALARM (red)	ON = Zone in alarm which has been acknowledged OFF = No Alarm FLASHING = Zone in alarm has not yet been acknowledged	If flashing press the ACK button to acknowledged the condition.
	SUPERVISORY (yellow)	ON = Zone has a supervisory condition which has been acknowledged (self-restoring condition) OFF = No supervisory condition exists FLASHING = Supervisory trouble detected on that zone that has not yet been acknowledged	If flashing press the ACK button to acknowledged the condition.
	TROUBLE (yellow)	ON = Zone has a trouble condition which has been acknowledged OFF = No zone trouble FLASHING = Zone has a trouble condition not yet acknowledged DOUBLE FLASHING = Zone was disabled CLEAN ME FLASHING = Indicates that the smoke detector needs cleaning	If flashing press the ACK button to acknowledged the condition. A “Clean Me Flash” is a flash with a long LED on Time and a short LED off time indicating that the smoke detector needs cleaning. Applies only to smoke detectors with the CLEAN ME feature. The “Clean Me” flash starts after the trouble condition has been acknowledge.
NAC 1 Through NAC 3	ACTIVE (yellow)	ON = NAC is active during an alarm OFF = NAC is not active during alarm	
	TROUBLE (yellow)	ON = NAC has a trouble condition and was acknowledged OFF = No trouble condition FLASHING = NAC has a trouble condition not yet acknowledged DOUBLE FLASHING = Circuit was disabled	If flashing press the ACK button to acknowledged the condition.

6.2 Operation Keys (Switches)

All system operation are performed from the on-board touchpad (switches) as described in the chart below.



Figure 6-2 On-Board Touchpad (Switches)

Table 6-2: Operations and Instructions

Operation	Keystrokes
To disable a notification appliance circuit.	Press the appropriate [NAC DISABLE] key. The NAC circuit will be disabled and the corresponding TROUBLE LED will Double Flash. This function is not available during an alarm condition.
To re-enable a notification circuit	Press The appropriate [NAC DISABLE] again.
Disable a zone.	Press the appropriate [ZONE DISABLE] key. The zone will be disabled and the corresponding TROUBLE LED will Double Flash. This function is not available during an alarm or supervisory condition.
To re-enable a zone.	Press the appropriate [ZONE DISABLE] again.
Begin Walk Test	Press [WALK TEST]. Walk Test LED turns on. Note: Walk test will not activate if the control panel has a trouble, alarm, or supervisory condition.
End Walk Test (The test ends automatically after 10 minutes of no system activity.)	Press [WALK TEST].
Acknowledge condition (alarm, supervisory, trouble)	Press [ACK]. The corresponding LED will change from blinking to steady for the duration of the condition. Except for CLEAN ME trouble indications.
Silence Panel	Press [SILENCE]. This will silence the on-board PZT and all active NAC circuits that have been configured as "silenceable".
Perform system reset	Press [RESET]. Resets alarms, supervisories, troubles and all LEDs.
To send a dialer test to your central station.	Press the [DIALER TEST] button.
To reset the dialer.	Press the [DIALER RESET] button.

Appendix A

Compatible Devices

This section of the manual lists devices (smoke detectors and notification appliances) that are compatible with the SK-6324. Silent Knight if you have a question about whether a device not listed here is compatible.

A.1 Smoke Detectors

This section of the manual contains information about smoke detectors that are compatible with the SK-6324.

	SK-6324
Identifier	24F
Voltage Range	17.3-28 VDC

Note: The maximum number of smoke detectors per zone is determined by both the current draw and the impedance of the smoke detector. If too many smoke detectors are used on any zone, false alarms could occur.

Do not mix different models of detectors on any zone; false alarms could occur.

A.1.1 Enhanced Mode

Enhanced mode allows the installer to use pull stations on a loop that has been programmed for Enhanced Alarm Verification. If a single detector goes into alarm it will start the alarm verification cycle. If a pull station is activated any time during the alarm verification cycle and after the control panel re-applies loop power (power will drop for seven seconds to restore detector during verification), the panel will go into immediate alarm and discontinue the verification cycle.

Warning! Do not mix different models or manufacturers of smoke detectors on the input loops.

A.1.2 Two-Wire Smoke Detectors

The table below lists two-wire smoke detectors that are compatible with the SK-6324. The table is organized by manufacturer. The columns show the number of detectors per loop that can be used. Two-wire Compatibility Identifier 24F.

Note: The check mark by manufacturers name indicates that this device can be used in enhanced mode.

Table A-1: Compatible Two-Wire Smoke Detectors

Manufacturer	Enhance Mode Compatible	Model Name or Number (Base model name or number in parentheses.)	Compatibility ID		# per Loop
			Head	Base	
Apollo	✓	55000-350 (45681-200)	55000-350	45681-200	24 / loop
	✓	55000-250 (45681-200)	55000-250	45681-200	24 / loop
Detection Systems		DS250 (MB2W or MB2WL)	B	A	18 / loop
		DS250HD (MB2W or MB2WL)	B	A	18 / loop
		DS250TH (MB2W or MB2WL)	B	A	18 / loop
ESL	✓	429C (S10A)	N/A	S10A	30 / loop
	✓	429CRT (S11A)	N/A	S11A	30 / loop
	✓	429CST (S11A)	N/A	S11A	30 / loop
	✓	429CT (S10A)	N/A	S10A	30 / loop
	✓	521B	N/A	S10A/S11A	40 / loop
	✓	521BXT	N/A	S10A/S11A	40 / loop
	✓	609U01-11	S10	S00	40 / loop
	✓	609U02-11	S10	S00/S03	40 / loop
	✓	611U (601U or 602U)	S10	S00/S03	40 / loop
	✓	611UD (601U or 602U)	S10	S00/S03	40 / loop
	✓	611UT (601U or 602U)	S10	S00/S03	40 / loop
	✓	612U (601U or 602U)	S10	S00/S03	40 / loop
	✓	612UD (601U or 602U)	S10	S00/S03	40 / loop
	✓	711U (701E or 701U)	N/A	S10A	25 / loop
	✓	712U (701E or 701U)	N/A	S10A	25 / loop
	✓	713-5U (702E or 701U)	N/A	S10A	25 / loop
	✓	713-6U (702E or 701U)	N/A	S10A	25 / loop
	✓	721-U (S10A)	N/A	S10A	30 / loop
	✓	721-UT (S10A)	N/A	S10A	30 / loop
Falcon		525	FDT1	N/A	17 / loop
		525T	FDT1	N/A	17 / loop

Table A-1: Compatible Two-Wire Smoke Detectors

Manufacturer	Enhance Mode Compatible	Model Name or Number <i>(Base model name or number in parentheses.)</i>	Compatibility ID		# per Loop
			Head	Base	
System Sensor		1100	A	N/A	20 / loop
		1400	A	N/A	20 / loop
		1451 (B401B)	A	A	20 / loop
		2300T	A	N/A	20 / loop
		2300	A	N/A	20 / loop
		2300TB	A	N/A	20 / loop
		2400	A	N/A	20 / loop
		2451 (B401B)	A	N/A	20 / loop
		2451DH (DH 400)	A	N/A	20 / loop
		2451TH (B401B)	A	N/A	20 / loop

Four-Wire Smoke Detectors

Table A-2: Compatible Four-Wire Smoke Detectors

Manufacturer	Model
Silent Knight	SD-P24F with SD-B4@ base
Detection Systems	DS200/DS200HD MB200
ESL	445 Series 449 Series
Gentex	624 824 2040-24 Power Supervision Unit
System Sensor	1851B 2851/2851BTH DH200ADCD

A.2 Notification Appliances

The chart below lists notification appliances compatible with the SK-6324

Table A-3: Compatible Notification Devices

Manufacturer	Model	Type
Faraday	446X 12/24VDC	Vibrating Bell
Faraday	476X 12/24VDC	Vibrating Bell
Faraday	477X 12/24VDC	Single Stroke Bell
Faraday	5303B-0-14-()-DC	Chime (flush)
Faraday	5304B-0-14-()-DC	Chime (surface)
Faraday	5305B-0-4-()-DC	Chime (ceiling)
Faraday	5306B-0-14-()-24-DC	Chime/Strobe (flush)
Faraday	5307B-0-14-()-24-DC	Chime/Strobe (surface)
Faraday	5308B-0-4-()-24-DC	Chime/Strobe (ceiling)
Faraday	5333B-0-14-24-DC	Multi-Tone Horn (flush)
Faraday	5334B-0-14-24-DC	Multi-Tone Horn (surface)
Faraday	5336B-()-14-24-DC	Multi-Tone Horn/Strobe (flush)
Faraday	5337B-()-14-24-DC	Multi-Tone Horn/Strobe (surface)
Faraday	5338B-()-4-24-DC	Multi-Tone Horn/Strobe (ceiling)
Faraday	5343B-0-14-24-DC	Single Tone Horn/Strobe (flush)
Faraday	5344B-0-14-24-DC	Single Tone Horn/Strobe (surface)
Faraday	5345B-0-4-24-DC	Single Tone Horn/Strobe (ceiling)
Faraday	5348B-()-4-24-DC	Single Tone Horn/Strobe (ceiling)
Faraday	5373B-0-14-24-DC	8-Tone Horn/Strobe (flush)
Faraday	5374B-0-14-24-DC	8-Tone Horn/Strobe (surface)
Faraday	5375B-0-4-24-DC	8-Tone Horn/Strobe (ceiling)
Faraday	5376B-0-14-24-DC	8-Tone Horn/Strobe (flush)
Faraday	5377B-0-14-24-DC	8-Tone Horn/Strobe (surface)
Faraday	5378B-0-4-24-DC	8-Tone Horn/Strobe (ceiling)
Faraday	5405B-0-14-24-DC	Sync Control Unit
Faraday	5508B-()-14-24-DC	Single Gang Sync Strobe (flush)
Faraday	5521B-()-14-24-DC	4" Square Sync Strobe (surface)
Faraday	5522B-()-14-24-DC	4" Square Sync Strobe (flush)
Faraday	6126B-U-14-24 VDC	Horn/Strobe
Faraday	6223B-0-14-24-DC	Horn (flush)
Faraday	6224B-0-14-24-DC	Horn (surface)
Faraday	6225B-0-4-24-DC	Horn (ceiling)
Faraday	6226B-()-14-24-DC	Horn/Strobe (flush)
Faraday	6227B-()-14-24-DC	Horn/Strobe (surface)

Table A-3: Compatible Notification Devices

Manufacturer	Model	Type
Faraday	6228B-()-4-24-DC	Horn/Strobe (ceiling)
Faraday	6243B-0-14-24-DC	Electron-Mechanical Horn (flush)
Faraday	6244B-0-14-24-DC	Electron-Mechanical Horn (surface)
Faraday	6245B-0-4-24-DC	Electron-Mechanical Horn (ceiling)
Faraday	6246B-()-14-24-DC	Electron-Mechanical Horn/Strobe (flush)
Faraday	6247B-()-14-24-DC	Electron-Mechanical Horn/Strobe (surface)
Faraday	6248B-()-4-24-DC	Electron-Mechanical Horn/Strobe (ceiling)
Faraday	6300B-0-14-24-DC	Mini-Horn (flush)
Faraday	6301B-0-14-24-DC	Mini-Horn (surface)
Faraday	6302B-()-4-24-DC	Mini-Horn (ceiling)
Faraday	6310B-0-14-24-DC	Mini-Horn/Strobe/Strobe (flush)
Faraday	6311B-0-14-24-DC	Mini-Horn/Strobe/Strobe (surface)
Faraday	6312B-()-14-24-DC	Mini-Horn/Strobe/Strobe (ceiling)
Faraday	6320B-0-14-24-DC	Sync Mini Horn/Strobe (1 gang)
Faraday	6321B-0-14-24-DC	Sync Mini Horn/Strobe (1,2 gang)
Faraday	6322B-()-14-24-DC	Mini Horn/Sync Strobe (1,2 gang, 4SQ)
Federal Signal	450	Horn
Federal Signal	VALS	Horn/Strobe
Gentex	GX90-4	Horn
Gentex	GXS-4-15-1	Strobe
Gentex	GXS-4-1575	Strobe
Gentex	GX90S-4-15	Horn
Gentex	GX90S-4-1575	Horn
Gentex	HG124	Horn
Gentex	SHG24-1575	Horn/Strobe
Gentex	SHG24-15	Horn/Strobe
Gentex	GMH-24-X	Horn
Gentex	GMS-24-X	Horn/Strobe
Gentex	GMS-24-X	Horn/Strobe
Gentex	GOT24	Horn
Gentex	GOS24-X	Horn
Gentex	WGMS-24-X	Horn/Strobe
System Sensor	MASS241	Horn/Strobe
System Sensor	MASS24110ADA	Horn/Strobe
System Sensor	MASS2415ADA	Horn/Strobe
System Sensor	MASS2475ADA	Horn/Strobe
System Sensor	SS4110ADA	Strobe
System Sensor	SS2415ADA	Strobe

Table A-3: Compatible Notification Devices

Manufacturer	Model	Type
System Sensor	SS2475ADA	Strobe
System Sensor	PS2415ADA	Mini-Horn/Strobe
System Sensor	PS241575ADA	Mini-Horn/Strobe
System Sensor	PS24110ADA	Mini-Horn/Strobe
System Sensor	PS2475ADA	Mini-Horn/Strobe
Wheelock	46T-G4-24-R	Bell
Wheelock	46T-G6-24-R	Bell
Wheelock	46T-G10-24-R	Bell
Wheelock	46T-G6-24-WS-24-HF-R	Strobe/Bell
Wheelock	46T-G10-24-WS-24-HF-R	Strobe/Bell
Wheelock	46T-G6-24-WH-24-HF-R	Strobe/Bell
Wheelock	46T-G10-24-WH-24-HF-R	Strobe/Bell
Wheelock	700IT-12\24-W-FR	Strobe Horn
Wheelock	7002T-12\24-W-FR	Strobe Horn
Wheelock	AES-DL1-R	Multitone Horn
Wheelock	AES-EL1-R	Multitone Horn
Wheelock	AES-DL1-WS-24-VF-R	Multitone Horn
Wheelock	AES-EL1-WS-24-VF-R	Multitone Horn
Wheelock	AES-DL1-WH-24-VF-R	Multitone Horn
Wheelock	AES-EL1-WH-24-VF-R	Multitone Horn
Wheelock	AES-DL1-WM-24-VF-R	Multitone Horn
Wheelock	AES-EL1-WM-24-VF-R	Multitone Horn
Wheelock	AH-24-R	Horn
Wheelock	AH-24WP-R	Horn
Wheelock	AMT-12\24-R	Strobe Horn
Wheelock	AMT-24-LS-VFR	Strobe Horn
Wheelock	AMT-24-LSM-VFR	Strobe Horn
Wheelock	AMT-24-IS-VFR	Strobe Horn
Wheelock	AS2415W-FR	Audible Strobe
Wheelock	AS241575W-FR	Audible Strobe
Wheelock	AS2430W-FR	Audible Strobe
Wheelock	AS2475W-FR	Audible Strobe
Wheelock	AS24110W-FR	Audible Strobe
Wheelock	AS2415C-FW	Audible Strobe
Wheelock	AS2430C-FW	Audible Strobe
Wheelock	AS2475C-FW	Audible Strobe
Wheelock	AS24100C-FW	Audible Strobe
Wheelock	AS-2415-VFR	Strobe Horn

Table A-3: Compatible Notification Devices

Manufacturer	Model	Type
Wheelock	AS-241575-VFR	Strobe Horn
Wheelock	AS-2430-VFR	Strobe Horn
Wheelock	AS-2475-VFR	Strobe Horn
Wheelock	AS-24110-HFR	Strobe Horn
Wheelock	SM-12/24-R	Strobe Horn Controller
Wheelock	DSM-12/24-R	Strobe Horn Controller
Wheelock	CF-BF1	Chime
Wheelock	CF-BF1-R	Chime
Wheelock	CH70-24-R	Chime
Wheelock	CH90-24-W	Chime
Wheelock	CH70-2415W-FR	Chime Strobe
Wheelock	CH70-241575W-FR	Chime Strobe
Wheelock	CH70-2430W-FR	Chime Strobe
Wheelock	CH70-2475W-FR	Chime Strobe
Wheelock	CH70-24110W-FR	Chime Strobe
Wheelock	CH-CF1	Chime
Wheelock	CH-CF1-R	Chime
Wheelock	CH-CF1-W	Chime
Wheelock	CH-DF1	Chime
Wheelock	CH-DF1-R	Chime
Wheelock	CH-BF1-WS-24-HF-R	Strobe Chime
Wheelock	CH-CF1-LS-24	Strobe Chime
Wheelock	CH-CF1-MS-24	Strobe Chime
Wheelock	CH-CF1-IS-24	Strobe Chime
Wheelock	CH-CF1-LS-24-CFW	Strobe Chime
Wheelock	CH-CF1-MS-24-CFW	Strobe Chime
Wheelock	CH-CF1-IS-24-CFW	Strobe Chime
Wheelock	CH-CF1-WS-24-CF-W	Strobe Chime
Wheelock	CH-DF1-LS-24	Strobe Chime
Wheelock	CH-DF1-MS-24	Strobe Chime
Wheelock	CH-DF1-IS-24	Strobe Chime
Wheelock	CH-DF1-LS-24-VFR	Strobe Chime
Wheelock	CH-DF1-LSM-24-VFR	Strobe Chime
Wheelock	CH-DF1-MS-24-VFR	Strobe Chime
Wheelock	CH-DF1-IS-24-VFR	Strobe Chime
Wheelock	CH-DF1-WM-24-VFR	Strobe Chime
Wheelock	CH-DF1-WS-24-VF-R	Strobe Chime
Wheelock	DSM-12/24	Sync Module

Table A-3: Compatible Notification Devices

Manufacturer	Model	Type
Wheelock	EH-DL1-R	Electronic Horn
Wheelock	EH-EL1-R Electronic Horn	Electronic Horn
Wheelock	EHS-DL1-W-VF-R	Strobe Horn (single input)
Wheelock	EHS-EL1-W-VF-R	Strobe Horn (single input)
Wheelock	EH-DL1-WS-24-VF-R	Strobe Horn (dual input)
Wheelock	EH-EL1-WS-24-VF-R	Strobe Horn (dual input)
Wheelock	EH-DL1-WH-24-VF-R	Strobe Horn (dual input)
Wheelock	EH-EL1-WH-24-VF-R	Strobe Horn (dual input)
Wheelock	EH-DL1-WM-24-VF-R	Strobe Horn (dual input)
Wheelock	EH-EL1-WM-24-VF-R	Strobe Horn (dual input)
Wheelock	HSW-24-HFR	Remote Strobe
Wheelock	HS2W-24-HFR	Remote Strobe
Wheelock	HSPW-24-HFR	Remote Strobe
Wheelock	IS-24-VFR	Remote Strobe
Wheelock	IS1-24-VFR	Remote Strobe
Wheelock	IS3-24-VFR	Remote Strobe
Wheelock	ISP-24-HFR	Remote Strobe
Wheelock	LS-24-VFR	Remote Strobe
Wheelock	LS1-24-VFR	Remote Strobe
Wheelock	LS3-24-VFR	Remote Strobe
Wheelock	LSP-24-HFR	Remote Strobe
Wheelock	LSM-24-VFR	Remote Strobe
Wheelock	LS1M-24-VFR	Remote Strobe
Wheelock	LS3M-24-VFR	Remote Strobe
Wheelock	LSPM-24-VFR	Remote Strobe
Wheelock	MS-24-VFR	Remote Strobe
Wheelock	MS1-24-VFR	Remote Strobe
Wheelock	MS3-24-VFR	Remote Strobe
Wheelock	MSP-24-HFR	Remote Strobe
Wheelock	MB-G6-24-R	Motor Bell
Wheelock	MB-G10-24-R	Motor Bell
Wheelock	MBS-G6-24-W-HF-R	Motor Bell with Strobe
Wheelock	MBS-G10-24-W-HF-R	Motor Bell with Strobe
Wheelock	MIZ-24-R	Mini-Horn
Wheelock	MIZ-24-W	Mini-Horn
Wheelock	MIZ-24-LS-VFR	Mini-Horn/Strobe
Wheelock	MIZ-24-LSM-VFR	Mini-Horn/Strobe
Wheelock	MIZ-24-MS-VFR	Mini-Horn/Strobe

Table A-3: Compatible Notification Devices

Manufacturer	Model	Type
Wheelock	MIZ-24-HSW-HFR	Mini-Horn/Strobe
Wheelock	MIZ-24-IS-VFR	Mini-Horn/Strobe
Wheelock	MIZ-24-WS-VF-R	Mini-Horn/Strobe
Wheelock	MIZ-24-WS-VF-W	Mini-Horn/Strobe
Wheelock	MIZ-24-WH-VF-W	Mini-Horn/Strobe
Wheelock	MIZ-24-WM-VF-W	Mini-Horn/Strobe
Wheelock	MT-12/24-R	Strobe Horn
Wheelock	MT4-12/24-R	Multitone Appliance
Wheelock	MT4-115-R	Multitone Appliance
Wheelock	MT-24-LS-VFR	Strobe Horn
Wheelock	MT-24-LSM-VFR	Strobe Horn
Wheelock	MT-24-MS-VFR	Strobe Horn
Wheelock	MT-24-IS-VFR	Strobe Horn
Wheelock	MT-24-SL-VFR	Strobe Horn
Wheelock	MT-24-SLM-VFR	Synch. Multitone Strobe
Wheelock	MT-24-WM	Strobe
Wheelock	MT-24-WM-VF-R	Horn
Wheelock	MT-24-WM-VFR	Strobe Horn
Wheelock	NH-12/24-R	Horn
Wheelock	NS-2415W-FR	Strobe Horn
Wheelock	NS-241575W-FR	Strobe Horn
Wheelock	NS-2430W-FR	Strobe Horn
Wheelock	NS-2475W-FR	Strobe Horn
Wheelock	NS-24110W-FR	Strobe Horn
Wheelock	NS4-2415W-FR	Strobe Horn
Wheelock	NS4-241575W-FR	Strobe Horn
Wheelock	NS4-2430W-FR	Strobe Horn
Wheelock	NS4-2475W-FR	Strobe Horn
Wheelock	NS4-24110W-FR	Strobe Horn
Wheelock	RS-2415W-FR	Strobe
Wheelock	RS-2415W-FR	Strobe
Wheelock	RS-241575W-FR	Strobe
Wheelock	RS-2415-HFR	Strobe
Wheelock	RSP-2415-VFR	Strobe
Wheelock	RS-241575-VFR	Strobe
Wheelock	RSP-241575-VFR	Strobe
Wheelock	RS-2430-VFR	Strobe
Wheelock	RS-2430-HFR	Strobe

Table A-3: Compatible Notification Devices

Manufacturer	Model	Type
Wheelock	RS-2475-VFR	Strobe
Wheelock	RSP-2475-HFR	Strobe
Wheelock	RS-24110-HFR	Strobe
Wheelock	RSP-24110-HFR	Strobe
Wheelock	RSS-2415W-FR	Strobe
Wheelock	RSS-241575W-FR	Strobe
Wheelock	RSS-2430W-FR	Strobe
Wheelock	RSS-2475W-FR	Strobe
Wheelock	RSS-24110W-FR	Strobe
Wheelock	RSS-2415C-FW	Strobe
Wheelock	RSS-2430C-FW	Strobe
Wheelock	RSS-2475C-FW	Strobe
Wheelock	RSS-24100C-FW	Strobe
Wheelock	RSSP-2415W-FR	Strobe
Wheelock	RSSP-241575-FR	Strobe
Wheelock	RSSP-2430W-FR	Strobe
Wheelock	RSSP-2475W-FR	Strobe
Wheelock	RSSP-24110W-FR	Strobe
Wheelock	SL-24-VFR	Synchronized Remote Strobe
Wheelock	SL1-24-VFR	Synchronized Remote Strobe
Wheelock	SL3-24-VFR	Synchronized Remote Strobe
Wheelock	SLP-24-VFR	Synchronized Remote Strobe
Wheelock	SLM-24-VFR	Synchronized Remote Strobe
Wheelock	SL1M-24-VFR	Synchronized Remote Strobe
Wheelock	SL3M-24-VFR	Synchronized Remote Strobe
Wheelock	SLPM-24-VFR	Synchronized Remote Strobe
Wheelock	SHW-24-VFR	Synchronized Remote Strobe
Wheelock	SH2W-24-VFR	Synchronized Remote Strobe
Wheelock	SHPW-24-VFR	Synchronized Remote Strobe
Wheelock	SCM-24-R	Controller for Synchronized Strobes
Wheelock	SM-12/24-R	Sync Module
Wheelock	SR-2415-VFR	Sync Strobe
Wheelock	SRP-2415-HFR	Sync Strobe
Wheelock	SR-241575-VFR	Sync Strobe
Wheelock	SRP-241575-VFR	Sync Strobe
Wheelock	SR-2475-VFR	Sync Strobe
Wheelock	SR-2475-HFR	Sync Strobe
Wheelock	SR-24110-HFR	Sync Strobe

Table A-3: Compatible Notification Devices

Manufacturer	Model	Type
Wheelock	SRP-24110-HFR	Sync Strobe
Wheelock	V700IT-12\24-W-FR	Strobe Horn
Wheelock	WM3T-24-FR	Remote Strobe
Wheelock	WM3T-24-VFR	Remote Strobe
Wheelock	WSIT-24-FR	Strobe
Wheelock	WS3T-24-FR	Strobe
Wheelock	WST-24-FR	Strobe

Silent Knight Fire Product Warranty and Return Policy

General Terms and Conditions

- All new fire products manufactured by Silent Knight after September 1, 1997 have a limited warranty period of 18 months from the date of manufacture against defects in materials and workmanship. See limited warranty statement for details.
- This limited warranty does not apply to those products that are damaged due to misuse, abuse, negligence, or have been modified in any manner whatsoever.

Repair and RA Procedure

- All products that are returned to Silent Knight for credit or repair require a RA (Return Authorization) number. Call Silent Knight Customer Service at 800-446-6444 or 612-493-6435 between 8:00 A.M. and 5:00 P.M. CST, Monday through Friday to obtain a return authorization number. Silent Knight Technical Support is available at 800-328-0103 between 8:00 A.M. and 6:00 P.M. CST, Monday through Friday.
- RA number must be prominently displayed on the outside of the shipping box. See return address example under Advanced Replacement Policy.
- All products returned to Silent Knight must be sent freight pre-paid. After product is processed, Silent Knight will pay for shipping product back to customer.
- Return the Silent Knight product circuit board only. Products that are returned in cabinets will be charged an additional \$20 to cover the extra shipping and handling costs over board only returns. Do not return batteries. Silent Knight has the authority to determine if a product is repairable. Products that are deemed un-repairable will be returned to the customer.
- Product that is returned that has a board date code more than 18 months from date of manufacture will be repaired and the customer will be assessed the standard Silent Knight repair charge for that model.
- A detailed description of the problem should be included with each return.

Advanced Replacement Policy

- Silent Knight offers an option of advance replacement for fire product printed circuit boards that fail during the 18 month warranty period.
- For advance replacement of a defective board call Silent Knight at 800-446-6444 or 612-493-6435 to obtain a RA (Return Authorization) number and request advanced replacement.
- Customers must use a MasterCard or Visa credit card to get an advance replacement.
- A new or refurbished board will be shipped to the customer. The customer will initially be billed for the replacement board but a credit will be issued after the repairable board is received at Silent Knight.
- The defective board must be returned within 30 days of shipment of replacement board for customer to receive credit. No credit will be issued if the returned board was damaged due to misuse or abuse.

- Repairs and returns should be sent to:

Silent Knight

Attn: Repair Department

7550 Meridian Circle

Maple Grove, MN 55369-4927

RA Number: _____

Limited Warranty

Silent Knight warrants that the products of its manufacture shall be free from defects in materials or workmanship for 18 months from the manufacturing date code on the printed circuit board, if such goods have been properly installed, are subject to normal proper use, and have not been modified in any manner whatsoever. Upon return of the defective product, Silent Knight will, at its sole discretion, either repair or replace, at no cost, such goods as may be of defective material or workmanship. Customers outside the United States are to return products to their distributor for repair.

SILENT KNIGHT SHALL NOT UNDER ANY CIRCUMSTANCES BE LIABLE FOR ANY INCIDENTAL OR CONSEQUENTIAL DAMAGES ARISING FROM LOSS OF PROPERTY OR OTHER DAMAGE OR LOSSES OWING TO THE FAILURE OF SILENT KNIGHT SECURITY SYSTEMS PRODUCTS BEYOND THE COST OF REPAIR OR REPLACEMENT OF ANY DEFECTIVE PRODUCTS.

SILENT KNIGHT MAKES NO WARRANTY OF FITNESS OR MERCHANTABILITY AND NO OTHER WARRANTY, ORAL OR WRITTEN, EXPRESS OR IMPLIED, BEYOND THE 18 MONTH WARRANTY EXPRESSLY SPECIFIED HEREIN.

SK-6324 Basic Operating Instructions P/N 151119 Rev. A

These instructions must be framed and displayed next to the SK-6324 panel in accordance with NFPA 72 fire code for Local Fire Alarm System.

LED (Color)		Function	Comments
AC POWER (green)		ON = Good AC OFF = Low AC trouble condition and it was acknowledged FLASHING = Unacknowledged AC Low trouble condition	If flashing press the ACK button to acknowledged the condition.
GENERAL TROUBLE (yellow)		ON = System trouble OFF = System OK FLASHING = At least one serial device is in trouble DOUBLE FLASHING = Two types of serial devices are in trouble.	
WALK TEST (yellow)		ON = Walk test is in progress OFF = Walk test is off. FLASHING = Walk test is on and at least one zone is not ready	Allow approximately 47 seconds between detector tests. In walk test when a detector is tripped it will cause an alarm for two seconds, then the control panel will drop power to the loop for seven seconds to reset the detector. Then an additional 38 seconds is needed to restore the detector. If verification is used the time between detector test will be about 2 minute and 30 seconds.
SYSTEM SILENCED (yellow)		ON = System audio output has been silenced OFF = Nothing silenced FLASHING = Partially silenced	When condition that caused audio activation clears, this condition will clear automatically. Note: Silencing an alarm will cause a general trouble condition.
GROUND FAULT (yellow)		ON = Ground fault condition exists and was acknowledged OFF = No fault FLASHING = A ground fault condition detected	If flashing press the ACK button to acknowledged the condition.
LOW BATTERY (yellow)		ON = Battery low condition that has been acknowledged OFF = Good battery condition FLASHING = Battery low condition	If flashing press the ACK button to acknowledged the condition.
ZONE 1 Through ZONE 6	ALARM (red)	ON = Zone in alarm which has been acknowledged OFF = No Alarm FLASHING = Zone in alarm has not yet been acknowledged	If flashing press the ACK button to acknowledged the condition.
	SUPERVISORY (yellow)	ON = Zone has a supervisory condition which has been acknowledged (self-restoring condition) OFF = No supervisory condition exists FLASHING = Supervisory trouble detected on that zone that has not yet been acknowledged	If flashing press the ACK button to acknowledged the condition.
	TROUBLE (yellow)	ON = Zone has a trouble condition which has been acknowledged OFF = No zone trouble FLASHING = Zone has a trouble condition not yet acknowledged DOUBLE FLASHING = Zone was disabled CLEAN ME FLASHING = Indicates that the smoke detector needs cleaning	If flashing press the ACK button to acknowledged the condition. A "Clean Me Flash" is a flash with a long LED on Time and a short LED off time indicating that the smoke detector needs cleaning. Applies only to smoke detectors with the CLEAN ME feature. The "Clean Me" flash starts after the trouble condition has been acknowledge.
NAC 1 Through NAC 3	ACTIVE (yellow)	ON = NAC is active during an alarm OFF = NAC is not active during alarm	
	TROUBLE (yellow)	ON = NAC has a trouble condition and was acknowledged OFF = No trouble condition FLASHING = NAC is in trouble DOUBLE FLASHING = Circuit was disabled	If flashing press the ACK button to acknowledged the condition.

Cut Along the Dotted Line

Operation	Keystrokes
Disable notification appliance circuit. To re-enable the circuit, press [NAC DISABLE] again.	Press the appropriate [NAC DISABLE] key. The NAC circuit will be disabled and the corresponding TROUBLE LED will Double Flash. This function is not available during an alarm condition.
Disable a zone To re-enable the circuit, press [ZONE DISABLE] again.	Press the appropriate [ZONE DISABLE] key. The zone will be disabled and the corresponding TROUBLE LED will Double Flash. This function is not available during an alarm or supervisory condition.
Begin Walk Test	Press [WALK TEST]. Walk Test LED turns on. Note: Walk test will not activate if the control panel has a trouble, alarm, or supervisory condition.
End Walk Test (The test ends automatically after 10 minutes of no system activity.)	Press [WALK TEST]. NOTE: The Walk Test feature is not operational during an alarm, supervisory or any system trouble condition.
Acknowledge condition (alarm, supervisory, trouble)	Press [ACK]. The corresponding LED will change from blinking to steady for the duration of the condition. Except for CLEAN ME trouble indications.
Silence Panel	Press [SILENCE]. This will silence the on-board PZT and all active NAC circuits that have been configured as "silenceable".
Perform system reset	Press [RESET]. Resets alarms, supervisories, troubles and all LEDs.
To send a dialer test to your central station.	Press the [DIALER TEST] button.
To reset the dialer.	Press the [DIALER RESET] button.

For Service Contact:	
----------------------	--

— — — — —

Cut Along the Dotted Line