

VoiceCom

Emergency Voice Alarm Communication System

ENGINEER AND ARCHITECT SPECIFICATIONS

-  Listed 864
- CSFM, NYMEA Approved
- Style Y (Class B) and Style Z (Class A) speaker and strobe circuits
- Power Supply and Battery Charger with output over-voltage protection
- Dry contact or polarity reversal activation
- Activation inputs are fully supervised
- High efficiency digital amplifier
- True 100 Watts RMS output capacity
- 25 or 70.7 VRMS audio (field selected)
- Up to 11 optional Speaker and Strobe supervision modules in one cabinet
- All outputs are power limited
- Stand-alone or for use with any Fire Alarm/Suppression Control panel
- Optional digital MessageMaker is field programmable
- Coded tone option
- Backup evacuation tone option



Description

The VoiceCom is a PRE-BUILT emergency voice and tone alarm communication system. The VoiceCom can be used as a stand alone system or in conjunction with any listed/approved fire alarm control panel. The VoiceCom is completely self-contained and has its own power supply, battery charger, brown-out supervision and transfer, earth-ground detection, trouble and trouble ring-back circuitry. It also incorporates an emergency paging microphone, tone generator, 50 Watt RMS audio amplifier and a speaker supervisory circuit. The power supply is capable of a full 3.5 Amps DC at 24 volts. A set of dry form "C" trouble contacts is provided for external connection to a fire alarm control panel or fire suppression system. Speaker and strobe circuits are supervised by the VoiceCom panel. The power supply is capable of charging up to 24 AH batteries although only 6 AH batteries are required for 24 hours of standby and 15 minutes of maximum alarm load operation.

Optional expansion of the VoiceCom system can be achieved with the use of speaker (101-SPK) and strobe (101-STRB) supervisory modules. Up to eleven speaker and/or strobe supervisory modules will mount in the same VoiceCom enclosure in any combination. An optional digital message unit called the MM-1 (MessageMaker) can be added in the place of two speaker or strobe zone modules (three zone spaces in the large cabinet option). The MM-1 comes pre-installed in the VoiceCom-MM system package. The MM-1 comes with 20 seconds of field programmable digital voice message capacity and 18 seconds of capacity for virtually any evacuation tone(s) required. Through the use of up to two optional 20 second "VOICE-CHIP" expansion devices, a message of up to 60 seconds can be recorded. The digital message can be recorded through audio coupling using the microphone on the MM-1 or electrically (with a tape recorder) using the headphone jack on the MM-1. The MM-1 MessageMaker comes with a standard test message, alert tone, alarm tone and a standard evacuation message which can be overwritten if a specific message and tone are required. The MM-1 MessageMaker has a built-in

sequencer which provides an ALERT tone followed by the emergency message, and in turn followed by the ALARM tone. The ALARM tone can be coded to conform to any local and national codes. The emergency message can be set to repeat up to seven times with the setting of DIP switches. The digital message can also be programmed to repeat until the system is reset. The MM-1 MessageMaker uses non-volatile memory thus retaining its messages indefinitely. As a further safeguard the 101-AMP amplifier module will activate an evacuation tone backup in the event of a MessageMaker failure.

Another optional digital message unit called the T-GEN can be added to the VoiceCom system. The T-GEN mounts directly onto the amplifier and requires no expansion module space. The tone and message repeats continuously when activated. The T-GEN comes with a standard alert tone, evacuation message, and whoop tone. These standard tones and message can be overwritten if another tone or message is required. The tone and message can be recorded using the built-in microphone or pre-recorded and downloaded using the telephone jack. Up to 60 seconds of alert tone, digital message, and alarm tone can be recorded on the T-Gen.

The auxiliary audio input can be used for connection to a remote paging microphone RMT-PG, telephone paging, or other required audio signal. The auxiliary audio input can be set to the lowest priority so that it will be disabled in the event of an alarm condition or when the system microphone button is pressed. The auxiliary audio input can also be set to the highest priority ensuring that the remote microphone RMT-PG has precedence over the VoiceCom microphone.

All the VoiceCom modules/options are centrally monitored for ground faults and supervision troubles. Troubles are annunciated on the panel via a LED and an audible trouble signal. A form "C" system trouble relay is used to create a trouble at the fire alarm control panel. The audible trouble signal may be silenced by activating the trouble silence button. Full annunciation of troubles is provided at both the main control panel and the individual modules. LEDs are provided for short circuit and open circuit trouble annunciation at every module. The system can be configured to give a reminder audible signal after the trouble has been acknowledged.

The basic VoiceCom provides 50 Watts RMS of voice and tone audio power per amplifier. Up to two amplifiers can be housed in VoiceCom's larger enclosure. The system can be configured in the field for 25 or 70.7 VRMS operation. It will meet the requirements of an "Assembly Occupancy" and other locations where voice and tone broadcasting is required. The VoiceCom incorporates a high efficiency amplifier that requires minimal energy for its operation. Up to 100 Watts RMS can be split in any ratio by up to twelve speaker circuits. Up to eleven strobe circuits can be housed in the VoiceCom cabinet to comply with requirements such as ADA. A remote reset input is available to reset the VoiceCom from a distant control panel. The VoiceCom can be made latching or non-latching thus requiring only two wires from the control panel for both alarm and reset functions.

The VoiceCom is capable of recognizing a short on a zone while the speech, tone, or strobe is active on other zones. Short circuited zones are isolated from the system and cause a zone trouble. The type of zone fault is annunciated at the zone card and a general system trouble audible signal and LED are activated at the main control module. Because of its full speaker zone isolation capabilities the VoiceCom meets the requirements specified by NFPA 72 for survivability.

Engineer And Architect Specification

The emergency voice and tone communication system shall be the Cerberus Pyrotronics model VoiceCom. The VoiceCom shall be a pre-built system and shall only require two wires from a

polarity reversal circuit or a dry contact for activation. It shall supervise the "NO" dry contact (if used) and provide a form "C" trouble relay activation in the event of a system fault. The VoiceCom shall incorporate 50 Watts true RMS amplifiers for both tone and speech amplification. The system shall have a load capacity of up to 100 watts. Optionally, the VoiceCom system shall be capable of providing 50 watts of audio with full backup. The VoiceCom shall be capable of operating as a stand alone system or follow the activation of the fire alarm/suppression system. The VoiceCom shall include a regulated power supply and shall be capable of charging and housing its own batteries. There shall be no need to calculate the load requirements or draw any energy from the fire alarm/suppression system. The VoiceCom shall come with one speaker supervisory zone as a standard and shall be capable of supervising any combination of up to eleven speaker (101-SPK) and/or strobe (101-STRB) monitoring modules.

A full set of control switches including an "all call," "tone interrupt," "trouble silence" and "reset" shall be available at the VoiceCom. The VoiceCom control panel shall also have a green "Power On" LED, a red "Alarm" LED, a yellow "Brown Out" LED and a yellow "System Trouble" LED.

The VoiceCom shall be able to detect a short on any speaker or strobe zone during the normal and alarm mode. The shorted zone shall be isolated from the system and a dedicated LED on the supervised zone shall indicate the individual short circuit condition. The system shall produce an audible and visual signal indicating that a trouble condition has occurred. Similarly an open circuit shall create a trouble condition and corresponding LED annunciation at the affected zone and at the main control module. Zones that are not shorted or opened shall remain operational.

The VoiceCom shall be able to detect a Brown-Out condition on the AC supply. In the Brown-Out condition the VoiceCom shall activate a dedicated LED and an audible trouble signal. Ground faults shall activate the system trouble LED and the audible trouble signal, as well as specific LEDs indicating negative and positive ground faults.

The VoiceCom shall be field configurable for 25 or 70.7 volt RMS audio output via program jumpers.

The VoiceCom shall have a digital message player/recorder option (MM-1). The digital message player/recorder shall be capable of storing alert and evacuation tones as well as an emergency voice message. It shall be possible to modify the digital message and tones in the field using a built-in acoustic microphone or a headphone jack connected to a tape recorder. There shall be no need for the burning of eeproms in order to program the digital message player/recorder. The digital message player/recorder shall be supervised by the VoiceCom. The VoiceCom shall provide a backup evacuation tone in the event of a digital message player/recorder failure.

An alarm condition shall cause an audible signal and a red LED to activate. A VoiceCom with a digital message player/recorder shall produce an ALERT tone followed by an emergency voice message, and in turn followed by an ALARM tone. The number of tone repetitions shall be configurable by the setting of DIP switches on the digital message player/recorder. A VoiceCom without a digital message player/recorder shall produce an evacuation "whoop" tone in the event of an alarm.

The sheet metal enclosure shall include a hinged deadfront allowing easy access to all the VoiceCom components for the purposes of wiring, setting the system configuration and servicing. A flush trim (CAB-TRIM) shall be available. A door with a key lock shall be part of the VoiceCom enclosure.

Ordering Information

VoiceCom Family of Pre-built Kits Ordering Information

VoiceCom, VoiceCom-R

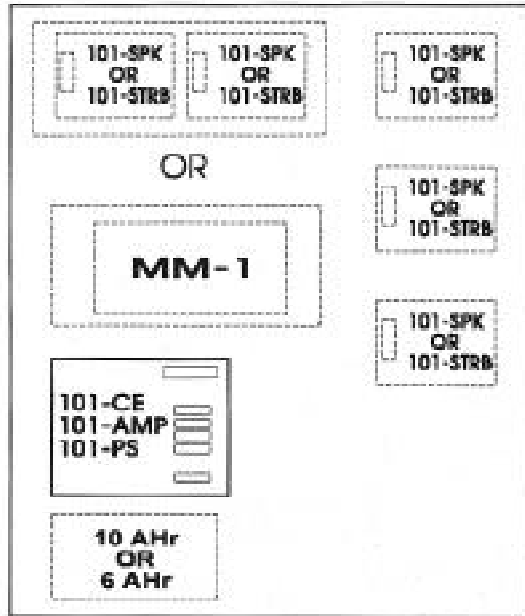

VoiceCom-MM, VoiceCom-MMR

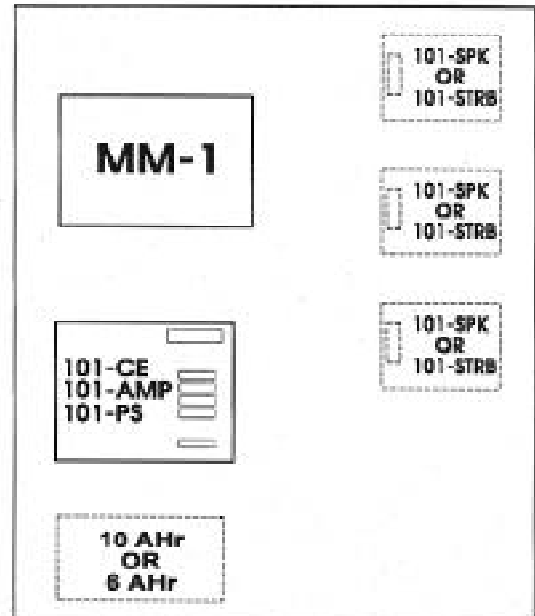

(Dimensions in inches: 20Hx15Wx5.4D)

VoiceCom-L, VoiceCom-LS
VoiceCom-LR, VoiceCom-LSR

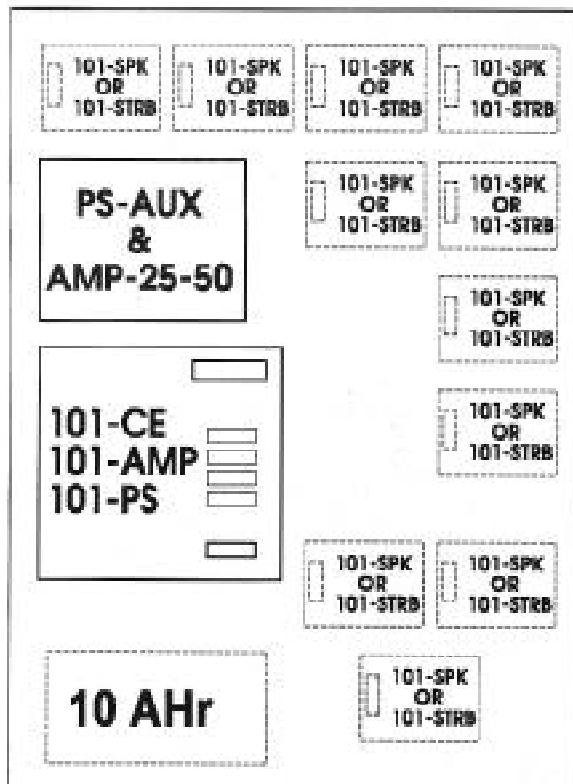

VoiceCom-MML, VoiceCom-MMLS
VoiceCom-MMLR, VoiceCom-MMLSR

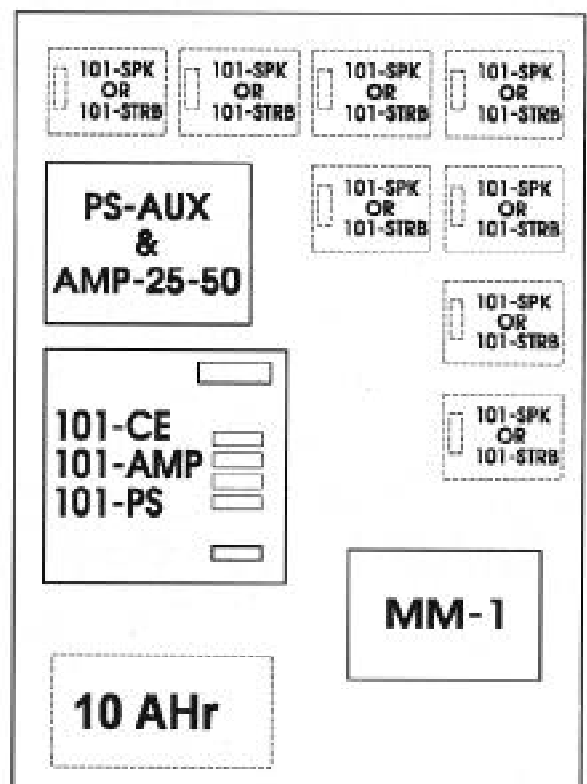

(Dimensions in inches: 32Hx18Wx5.56D)

* Items in dashed lines are optional and indicate possible expansion capacity

Chart 1. Ordering Information

Model	Part Number	Description
VoiceCom	500-693713	Pre-built system comes with: 3.5 Amp power supply and battery charger 50 Watt high efficiency amplifier (25/70.7 VRMS) Battery cables Main control board with one speaker circuit Paging microphone Black enclosure with deadfront (space for 5 zone modules).
VoiceCom-R VoiceCom-L	500-694226 500-694227	Same as VoiceCom with red cabinet VoiceCom system components in large enclosure with: Auxiliary power supply (PS-AUX), extra 50 Watt amplifier (AMP-25-50), space for 11 zone modules 4 PS-AUX Strobe Zone Cables 1 AM-25-50 Speaker Zone Cables (SYSTEM HAS A TOTAL OF 100 WATTS AMPLIFICATION)
VoiceCom-LS	500-694228	VoiceCom-L System components with the 50 Watt amplifier configured for standby only. (SYSTEM HAS A TOTAL OF 50 WATTS AMPLIFICATION)
VoiceCom-LR	500-694229	VoiceCom-L system in red enclosure
VoiceCom-LSR	500-694230	Same as the VoiceCom-LS in red enclosure
VoiceCom-MM	500-693714	Pre-built system comes with: VoiceCom components plus the MM-1 digital MessageMaker (Pre-installed). System has space for 3 zone modules
VoiceCom-MMR	500-694231	Same as VoiceCom-MM in red enclosure
VoiceCom-MML	500-694232	Same as VoiceCom-MM components in large black enclosure. Comes with auxiliary power supply (PS-AUX), additional 50 Watt amplifier (AMP-25-50) 4 PS-AUX Strobe Zone Cables 1 AMP-25-50 Speaker Zone Cable System has space for 8 zone modules (SYSTEM HAS A TOTAL OF 100 WATTS AMPLIFICATION)
VoiceCom-MMLS	500-694233	Same as VoiceCom-MML with the 50 Watt amplifier configured for standby only. (SYSTEM HAS A TOTAL OF 50 WATTS AMPLIFICATION)
VoiceCom-MMLR	500-694234	Same as VoiceCom-MML in a red enclosure
VoiceCom-MMLSR	500-694235	Same as VoiceCom-MMLS in a red enclosure
<i>Flush Trim for VoiceCom and VoiceCom-MM</i>		
CAB-TRIM	500-693720	Small cabinet semi-flush trim
CAB-TRIM2	500-694240	Large cabinet semi-flush trim
<i>Speaker and Strobe Expansion Modules</i>		
101-SPK	500-693715	One supervised speaker zone
101-STRB	500-693716	One supervised strobe zone
<i>MessageMaker with 20 Second Message (Takes 2 Module Spaces in small cabinet, 3 in large cabinet)</i>		
MM-1	500-693719	Digital MessageMaker
<i>Voice Message Expansion Chip(2 Maximum per MessageMaker)</i>		
VOICE-CHIP	500-693767	20 sec message expansion
<i>AutomaticTone/Voice Message Module</i>		
T-GEN	500-694238	T-Gen Tone/Message Unit
<i>Remote Paging Microphone</i>		
RMT-PG	500-693721	Remote paging mike
<i>Batteries</i>		
BT-33	175-387141	6 AH Battery set
BT-34	175-387140	10 AH Battery set

VoiceCom System Wiring Diagram

Figure 1

**LOADING CHART 1
SYSTEM LOADING**

Speaker Load (Watts)	Strobe Load (Amperes)
5	3.2
10	2.8
15	2.4
20	2.0
25	1.8
30	1.2
40	0.8
50	0.4

Capacity per Power Supply & Amplifier Pair

1 kΩ, 1W EOL

Note 3

SUPERVISED, POWER LIMITED INITIATING CIRCUIT, MAX 50 mA, RIPPLE < 300 mV, Style 'B', MAX IMPEDANCE: 30 OHMS

OPTIONAL CONNECTION TO FACP

Supervisory Voltage 11 V to 16 V DC

**SPEAKER CIRCUIT
STYLE 'Y' (CLASS 'B')
SHOWN,
SUPERVISED,
POWER
LIMITED OUTPUT
MAX: 50 W**

**STYLE 'Z', CLASS 'A'
SPEAKER CIRCUIT
REFER TO SYSTEM
LOADING CHART # 1**

FROM GREEN 'EARTH GROUND' WIRE FROM CHASSIS

SHOWN FOR STYLE 'Y'. ALL CIRCUITS SUPERVISED, POWER LIMITED. SUPERVISING VOLTAGE ACROSS NAC is 7 V TO 8 V DC. MAX RIPPLE CURRENT < 300 mV REFER TO SYSTEMS LOADING CHART #1 FOR SYSTEM LOADING

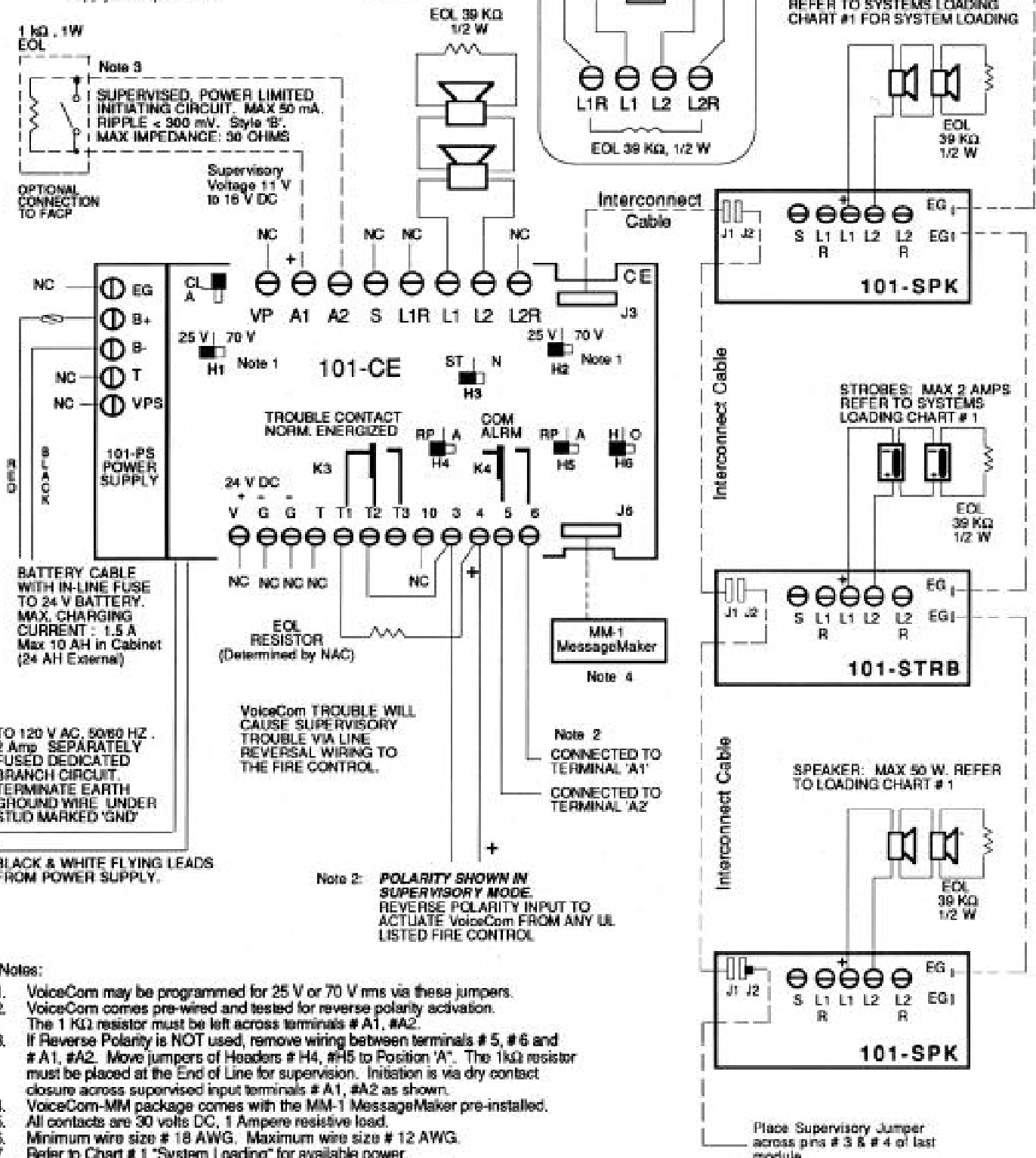

BATTERY CABLE WITH IN-LINE FUSE TO 24 V BATTERY. MAX. CHARGING CURRENT: 1.5 A Max 10 AH in Cabinet (24 AH External)

TO 120 V AC, 50/60 HZ. 2 Amp SEPARATELY FUSED DEDICATED BRANCH CIRCUIT. TERMINATE EARTH GROUND WIRE UNDER STUD MARKED 'GND'

BLACK & WHITE FLYING LEADS FROM POWER SUPPLY.

VoiceCom TROUBLE WILL CAUSE SUPERVISORY TROUBLE VIA LINE REVERSAL WIRING TO THE FIRE CONTROL.

Note 2
CONNECTED TO TERMINAL 'A1'
CONNECTED TO TERMINAL 'A2'

Note 2: POLARITY SHOWN IN SUPERVISORY MODE. REVERSE POLARITY INPUT TO ACTUATE VoiceCom FROM ANY UL LISTED FIRE CONTROL

STROBES: MAX 2 AMPS REFER TO SYSTEMS LOADING CHART # 1

SPEAKER: MAX 50 W. REFER TO LOADING CHART # 1

Place Supervisory Jumper across pins # 3 & # 4 of last module

Notes:

- VoiceCom may be programmed for 25 V or 70 V rms via these jumpers.
- VoiceCom comes pre-wired and tested for reverse polarity activation. The 1 kΩ resistor must be left across terminals # A1, #A2.
- If Reverse Polarity is NOT used, remove wiring between terminals # 5, # 6 and # A1, #A2. Move jumpers of Headers # H4, #H5 to Position 'A'. The 1kΩ resistor must be placed at the End of Line for supervision. Initiation is via dry contact closure across supervised input terminals # A1, #A2 as shown.
- VoiceCom-MM package comes with the MM-1 MessageMaker pre-installed.
- All contacts are 30 volts DC, 1 Ampere resistive load.
- Minimum wire size # 18 AWG. Maximum wire size # 12 AWG.
- Refer to Chart # 1 "System Loading" for available power.
- For Compatible Notification Appliances please refer to Chart 2.

100 Watt VoiceCom System Wiring Diagram

Figure 2

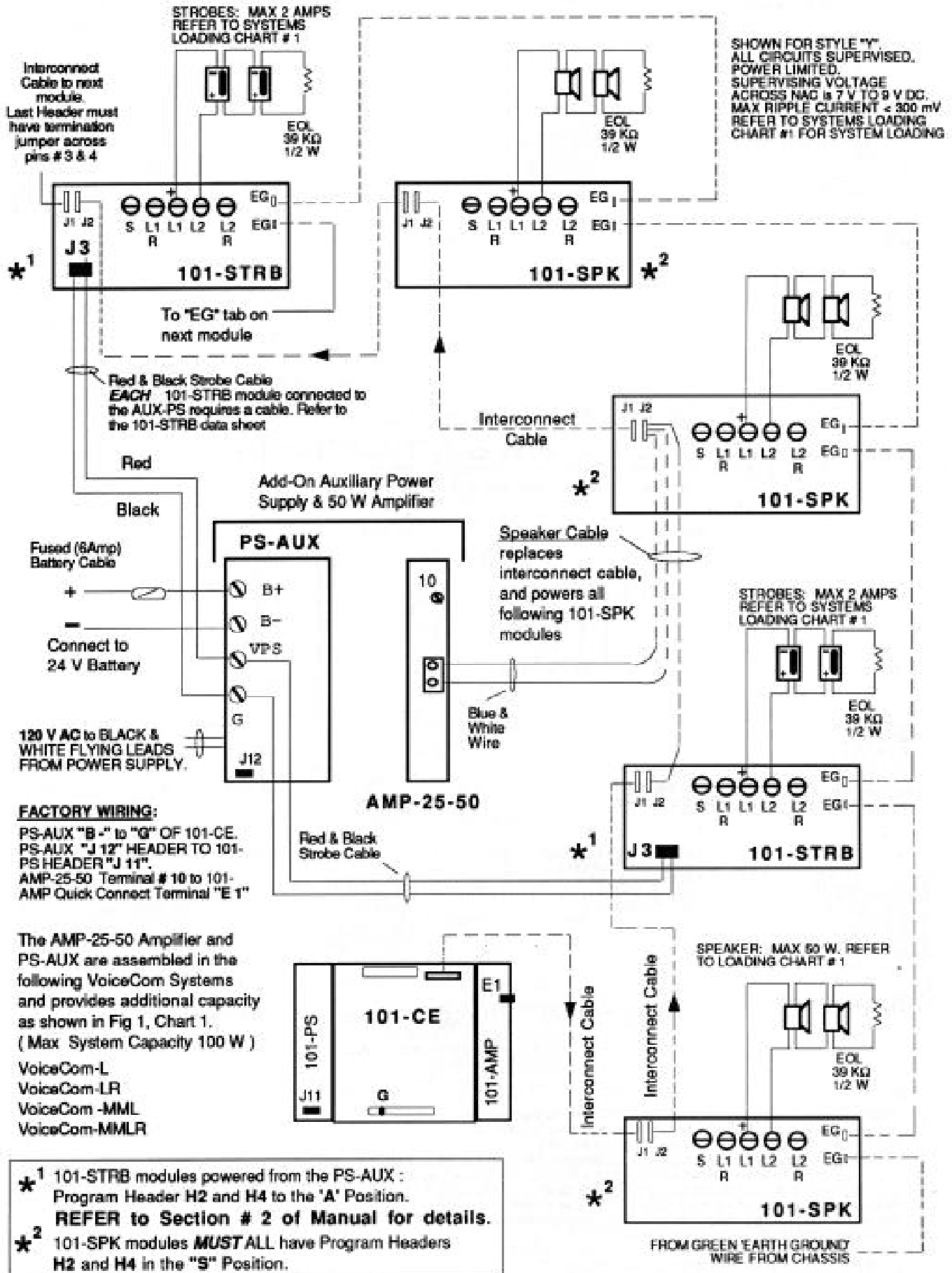

50 Watt VoiceCom System with Standby Wiring Diagram

Figure 3

CONNECTING Strobe Supervisory Modules (101-STRB) to the PS-AUX

The AMP-25-50 Amplifier and PS-AUX are assembled in the following VoiceCom Systems:

- The System provides 50 watts Standby Audio Power.
- VoiceCom-LS
- VoiceCom-LSR
- VoiceCom-MMLS
- VoiceCom-MMLSR

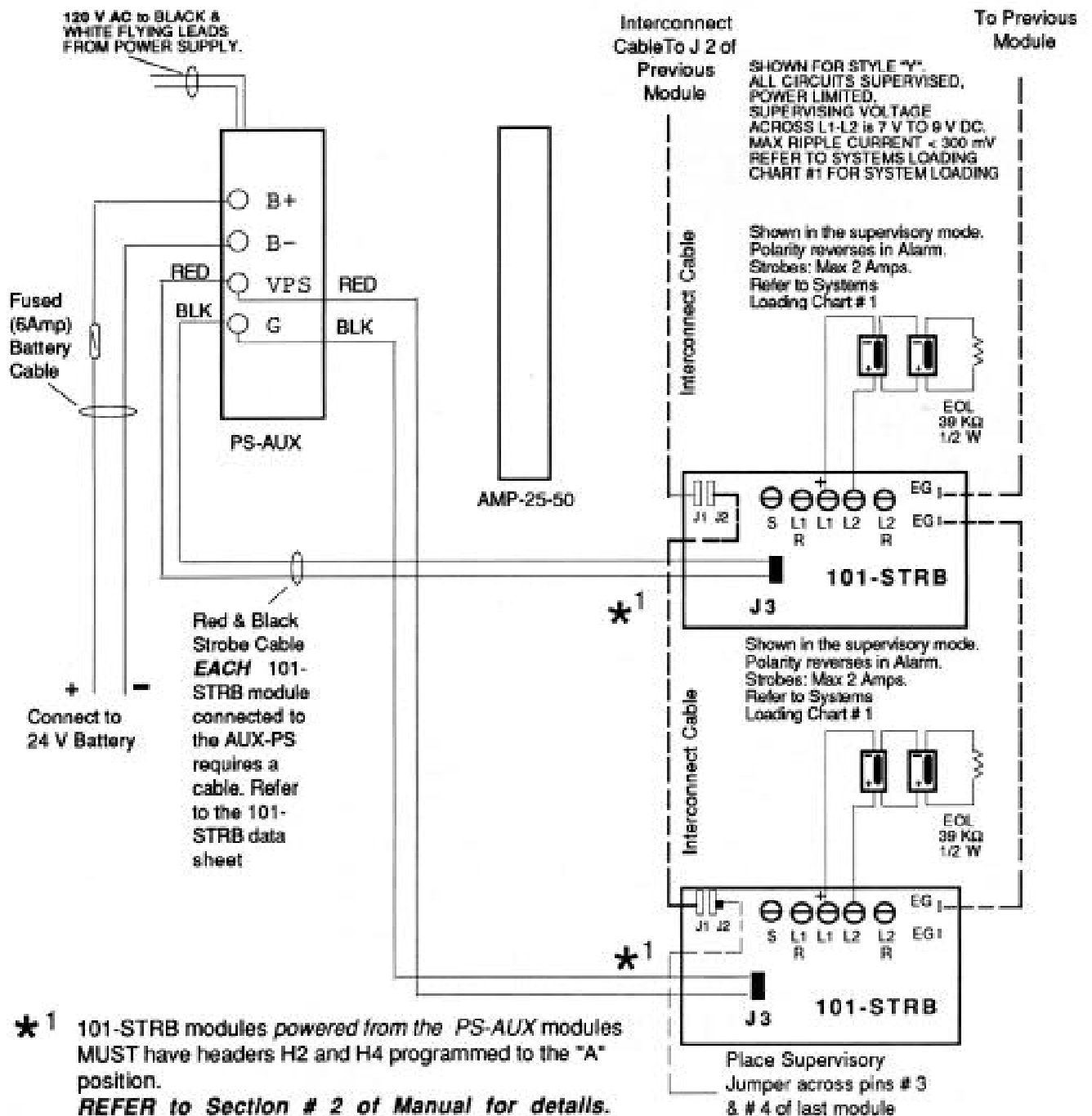

Chart 2. Compatible Notification Appliances

Category	Product	Category	Product	Category	Product	Category	Product
Strobes	SVMT-F SVM1T-F SVM3T-SO S15-STD S15-SGL S15-SUR S15-RET S30-STD S30-SGL S30-SUR S30-RET S75-STD S75-SGL S75-SUR S75-RET S15/75-STD S15/75-SGL S15/75-SUR S110-STD S110-SGL S110-RET S15-FS S15-F S15-FT S15-ST S15-S S17-FS S17-F S17-FT S17-ST S75-FS S75-F S75-S S75-FT S75-ST S110-FS S110-S S110-ST U-S17 U-S17-W U-S17-1 U-S17-1-W U-S17-C U-S17-W-C U-S30 U-S30-W U-S30-1 U-S30-1-W U-S30-C U-S30-W-C U-S60 U-S60-W U-S60-1 U-S60-1-W U-S60-C U-S60-W-C U-S75 U-S75-W U-S75-1 U-S75-1-W U-S75-C U-S75-W-C U-S110 U-S110-W U-S110-1 U-S110-1-W U-S110-C U-S110-W-C	Speakers	SL25-C SL25-F SL25-S SL25-C SL70-F SL70-S	Speaker Strobes (cont.)	I-SM70-S75-W I-SM25-S110 I-SM70-S110 I-SM25-S110-W I-SM70-S110-W I-SM25-C I-SM70-C I-SM25-S17-C I-SM70-S17-C I-SM25-S30-C I-SM70-S30-C I-SM25-S60-C I-SM70-S60-C I-SM25-S75-C I-SM70-S75-C I-SM25-S110-C I-SM70-S110-C I-SM70-R-C	Sync. Speaker Strobes	I-SH25-S17S I-SH70-S17S I-SH25-S17S-W I-SH70-S17S-W I-SH25-S30S I-SH70-S30S I-SH25-S30S-W I-SH70-S30S-W I-SH25-S60S I-SH70-S60S I-SH25-S60S-W I-SH70-S60S-W I-SH25-S75S I-SH70-S75S I-SH25-S75S-W I-SH70-S75S-W I-SH25-S110S I-SH70-S110S I-SH25-S110S-W I-SH70-S110S-W I-SH25-S17S-C I-SH70-S17S-C I-SH25-S30S-C I-SH70-S30S-C I-SH25-S60S-C I-SH70-S60S-C I-SH25-S75S-C I-SH70-S75S-C I-SH25-S110S-C I-SH70-S110S-C I-SM25-S17S I-SM70-S17S I-SM25-S17S-W I-SM70-S17S-W I-SM25-S30S I-SM70-S30S I-SM25-S30S-W I-SM70-S30S-W I-SM25-S60S I-SM70-S60S I-SM25-S60S-W I-SM70-S60S-W I-SM25-S75S I-SM70-S75S I-SM25-S75S-C I-SM70-S75S-C I-SM25-S110S-W I-SM70-S110S-W I-SM25-S17S-C I-SM70-S17S-C I-SM25-S30S-W I-SM70-S30S-W I-SM25-S60S I-SM70-S60S I-SM25-S60S-W I-SM70-S60S-W I-SM25-S75S I-SM70-S75S I-SM25-S75S-C I-SM70-S75S-C I-SM25-S110S-C I-SM70-S110S-C I-SM25-S75S-R-C
		Speaker Strobes	I-SH25 I-SH70 I-SH25-W I-SH70-W I-SH25-S17 I-SH70-S17 I-SH25-S17-W I-SH70-S17-W I-SH25-S30 I-SH70-S30 I-SH25-S30-W I-SH70-S30-W I-SH25-S60 I-SH70-S60 I-SH25-S60-W I-SH70-S60-W I-SH25-S75 I-SH70-S75 I-SH25-S75-W I-SH70-S75-W I-SH25-S110 I-SH70-S110 I-SH25-S110-W I-SH70-S110-W I-SH25-C I-SH70-C I-SH25-S17-C I-SH70-S17-C I-SH25-S30-C I-SH70-S30-C I-SH25-S60-C I-SH70-S60-C I-SH25-S75-C I-SH70-S75-C I-SH25-S110-C I-SH70-S110-C I-SM-25 I-SM-70 I-SM25-W I-SM70-W I-SM25-S17 I-SM70-S17 I-SM25-S17-W I-SM70-S17-W I-SM25-S30 I-SM70-S30 I-SM25-S30-W I-SM70-S30-W I-SM25-S60 I-SM70-S60 I-SM25-S60-W I-SM70-S60-W I-SM25-S75 I-SM70-S75 I-SM25-S75-W	Sync Strobes	S15S-F S15S-FS S15S-FT S15S-S S15S-ST S17S-F S17S-FS S17S-FT S17S-S S17S-ST S75S-F S75S-FS S75S-FT S75S-S S75S-ST U-S17S U-S17S-W U-S30S U-S30S-W U-S60S U-S60S-W U-S75S U-S75S-W U-S110S U-S110S-W U-S17S-1 U-S17S-1-W U-S30S-1 U-S30S-W U-S60S-1 U-S60S-1-W U-S75S-1 U-S75S-1-W U-S110S-1 U-S110S-1-W U-S17S-C U-S17S-W-C U-S30S-C U-S30S-W-C U-S60S-C U-S60S-W-C U-S75S-C U-S75S-W-C U-S110S-C U-S110S-W-C	These modules must be used with a Synchronizing control Module (DSC, DSC-W, SCM-F, or SCM-FW)	These modules must be used with a Synchronizing Control Module (DSC, DSC-W, SCM-F, or SCM-FW)

Cerberus Pyrotechnics
 8 Fernwood Road
 Florham Park, NJ 07932

Tel: (973) 593-2600
 FAX: (973) 593-6670
 Website: www.cerbpyro.com

7/00
 5M
 SCD-IG
 Printed in U.S.A.

Cerberus Pyrotechnics
 50 East Pearce Street
 Richmond Hill, Ontario
 L4B, 1B7 CN
 Tel: (905) 764-8384
 FAX: (905) 731-9182

Siemens Building Technologies
Cerberus Division

July 2000
 Supersedes sheet dated 7/99